

*Teacher's Handbook*

***the  
various  
language***

An Inquiry Approach  
to the Physical Sciences

***Arnold Arons***

Professor of Physics  
University of Washington

**OXFORD UNIVERSITY PRESS**

à  
N  
?

Lt 3872  
1987

NGÀY MUỘN

SỐ THẺ

**UN MONASTÈRE DANS L'ÉCONOMIE D'ÉCH**  
**les services de transport à l'abbaye Saint-Ge**  
**au IX<sup>e</sup> siècle\***

En 1947, les *Annales* publiaient un article  
« Au temps de Charlemagne et des Normands »



Lt 3872/1987

K K 2010

K.K. 1994

Teacher's Handbook  
for  
THE VARIOUS LANGUAGE  
An Inquiry Approach to the Physical Sciences

Arnold Arons  
Professor of Physics  
University of Washington



**HARVEY BLEND**

"To him who in the love of Nature holds  
Communion with her visible forms, she speaks  
A various language."

William Cullen Bryant  
Thanatopsis

New York  
Oxford University Press  
1977

3872  
Lt 4987  
0 Ph. 500

Copyright © 1977 by Oxford University Press, Inc.

Printed in the United States of America

## Table of Contents

Preface

Introduction, Part I: Basic philosophy of the course as detailed in article "Toward Wider Public Understanding of Science."

Introduction, Part II: Content and Structure of the course.

Introduction, Part III: Laboratory apparatus and supplies

Chapters 1 - 23: Pedagogical notes and comments. Test and examination questions.

## Preface

This handbook is intended to be of practical assistance to anyone undertaking to teach the course embodied in the text "The Various Language - An Inquiry Approach to the Physical Sciences." The following items are included:

- (a) A description of the basic educational philosophy underlying the course.
- (b) An outline of the structure, content, and story line of the course.
- (c) Chapter by chapter comments on the more significant learning problems that arise in connection with specific items of subject matter and brief statements concerning the way in which our experience has moulded our approach to these problems.
- (d) Lists of equipment needed for the experiments in each chapter.
- (e) Questions and problems that have been used in tests and examinations and for check of understanding at the end of each unit.

The basic structure of the course is designed for a PSI (personalized system of instruction) or "Keller Plan" format with each chapter forming a unit on which students should pass a competency test before moving on to the next unit in the sequence. Laboratory experiments and observations are embedded directly in the text material and are sequenced to precede concept formation and inductive generalization.

If the course is given in a class-and-lecture format, some of the experiments can be presented as lecture demonstrations while others can readily be transformed into take-home experiments or homework assignments. The intent of the inquiry-oriented structure would be violated only if the experiments and observations were carried out as ex post facto "verifications" of the verbal assertions originating in lecture presentations.

Seattle, Washington  
June 1976

## Toward Wider Public Understanding of Science

ARNOLD ARONS

Department of Physics  
University of Washington  
Seattle, Washington 98105

*Wider understanding of science will be achieved only by giving students a chance to synthesize experience and thought into knowledge and understanding. Such a chance is not available in the deluge of unintelligible names and jargon precipitated at unmanageable pace and volume in so large a proportion of our college courses, and it is not available in the absence of humanistic, historical, or philosophical perspectives within these courses. Neither will salvation be found in topical courses on currently "popular" matters such as the energy crisis, environmental problems, or societal impact—so long as these problems are plunged into without any genuine prior understanding of the underlying scientific ideas. Some deeply valuable lessons about the learning process, as it occurs in all individuals, are to be learned from among the best of the new elementary science curricula that are now available to the schools. These lessons are transferable to college level and might help us simultaneously develop a new generation of teachers who would begin to disseminate a wider public understanding of science through competent teaching of science in the elementary schools.*

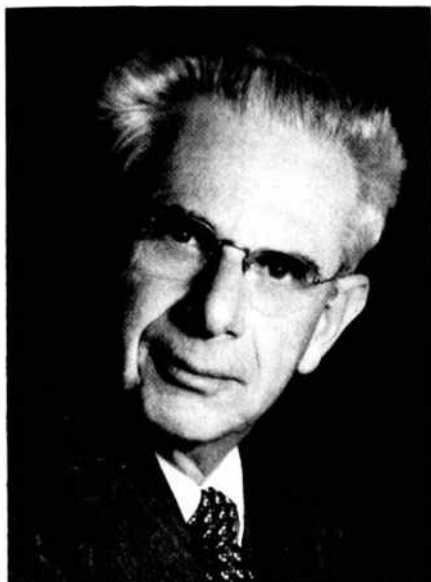

Editorializing recently in *Science*,<sup>1</sup> Amitai Etzioni remarks that

Vital to the success of the program [to enhance the public's understanding of the scientific enterprise] is a recognition of the distinction between scientific *information* and an *understanding* of science. The temptation is to treat science as a cornucopia of facts and to seek to share this bounty with all who are not yet so blessed . . . . To understand science, one must learn to appreciate the value, validity, and vitality of an empirical-logical approach to the world . . . one must acquire a taste, or at least a tolerance, for the beauty of mathematical models, of the structure of galaxies or crystals, of DNA . . . . The public must learn that scientific findings are always tentative and may prove erroneous or obsolescent, but that their tentative guide is more valid and safe than any other approach to the world.

Campaigns to achieve better public understanding of science are, of course, not new and there is a long history of particularly strong efforts to reach at least the college and university population through courses and through curricular requirements. Yet, as sympathetically oriented a humanist as H. J. Muller is led to remark

Although all students of the humanities have had a course or so in some science in which they picked up some technical knowledge together with probably fallacious notions about "the" scientific method, most know little about the history, philosophy, and sociology of science, or about how and why it has revolutionized thought and life. They have no clear idea what questions science can and cannot answer, why its answers are always partial and dubitable, why its triumphant advance may make the humanities all the more important, or why these are not living merely on left-overs. They have a legitimate excuse in that introductory courses in science are usually taught as technical courses, a

basis for more advanced work, not as humanistic studies for nonspecialists, or even as introductions to the fundamental question—the nature of scientific inquiry.... Students of literature in particular may share the traditional attitude reflected in T. S. Eliot's "Notes Toward the Definition of Culture," in which he completely ignored science....<sup>2</sup>

The ignorance that Muller deplors pervades the outlook of most students of science as well as of students of the humanities. As he points out, science curricula are generally barren of the intellectual content he defines, and the relevant humanistic insights do not automatically penetrate the walls of the nonscience compartments to which the "humanities requirements" are confined.

Similarly, the vast majority of so-called "general education science courses" or "courses for non-science majors" have no more cultural impact than the introductory courses for majors—the recent plethora of "\_\_\_\_\_ for Poets" books notwithstanding. I submit that most of these efforts founder—and will continue to founder—because they almost invariably confront their victims with little more than an incomprehensible stream of technical jargon, not rooted in any experience accessible to the student himself, and presented much too rapidly and in far too high a volume for the assimilation of any significant understanding of ideas, concepts, or theories. The pace precludes the development of any sense of how concepts and theories originate, how they come to be validated and accepted, how they connect with and elucidate experiences other than the particular ones glibly and superficially asserted in the text—much less allowing reflection on the scope and limitations of scientific knowledge or its impact on our intellectual heritage and view of our position in the natural universe. The "stream of words" approach has not solved and will not solve our educational problem—even if it is loaded with handsome illustrations and salted with allusions to pollution, energy crises, black holes, and Kafka.

It seems to me that, at the present moment, there are two major channels through which positive educational attainments of the kind advocated by Etzioni and Muller could be

promptly and widely injected into college-level science teaching. I shall discuss these in sequence without attempting to deal with many other undeniably important elements of curricular structure or with the horde of operational facets of teaching. One of these channels resides in giving students time to study and develop a genuine understanding of a limited number of significant scientific ideas by synthesis of their own experience and thought rather than through a rapid, unintelligible, verbal barrage of names and asserted end results; the second resides in bringing a more articulate historical, philosophical, and sociological content directly into all science courses—particularly those at introductory levels.

#### ELEMENTARY SCHOOL SCIENCE CURRICULA

The finest, liveliest, and pedagogically most effective curricular materials currently available for teaching concepts and subject matter of science are to be found not at college or secondary-school levels but among some of the new materials being released, after long periods of trial, development, and revision, for use in the elementary schools.<sup>3-6</sup> The groups that developed these materials worked directly with the children they sought to teach and met the latter on their own ground and at their existing verbal and conceptual starting points rather than in some never-never land of unchecked, untested hypotheses and assumptions about children and learning. In these materials, concepts are developed through experience, induction, and synthesis, with the teacher as guide and pilot rather than verbal inculcator. Ideas are developed *first*—out of direct experience, in terms of prior, familiar vocabulary, regardless of how cumbersome the latter might be—and technical terms are generated operationally only *after* experience has given them sanction and meaning.

The essence of instruction with these materials, whether the subject matter is physical or biological, is to give the children *time*—time to explore, to test, to manipulate, to suggest hypotheses, to follow trails to dead ends and to retrace their steps, and to make mistakes and to recognize and correct them on their own initiative without being punished for being "wrong." In other words, children learn from experience rather than from verbal inculcation. This is not to suggest



that they are expected to be Newtons, Faradays, Agassizes, and Darwins who independently re-discover the structure of science *de novo* by the age of ten; they are ordinary, lively, curious, fun-loving children who react to the opportunity to learn from perceptively guided experience and observation. They retain what they have learned because they are synthesizing genuine experience and not just memorizing a jumble of unfamiliar words. They know where their knowledge comes from, on what evidence it is based, and they are capable of addressing the very sophisticated questions: "How do we know . . .?" "Why do we believe . . .?" "What is the evidence for . . .?"

But these materials are by no means "teacher-proof." They can be handled effectively only by teachers who hold a deep enough understanding of the subject matter to possess the security and flexibility to lead investigation rather than to dictate end results; to accept incorrect suggestions or hypotheses, recognize the misconception in the child's mind, and guide him into revision and correction of his ideas rather than rejecting them by assertion and insisting on a memorized conclusion.

Were these new materials (together with existing new curricula in middle schools and high schools) suddenly effectively implemented throughout our schools, we would have an entirely different problem of science education in the colleges—one that we are *totally* unprepared for, but one that might, at this level, be somewhat more successfully handled with the verbal methods we now use. This millennium is still very far off because, among other reasons, we have not generated a corps of teachers prepared to handle the new materials effectively. We—the college-university community—"educated" the teachers, and the condition in which we have left them is depressing evidence of the total inadequacy of what we are now doing.

Since the envisaged millennium is not immediately at hand, we might, for the time being at the college level, profit from the example set by the new elementary school teaching materials and follow their mode and pattern (at an appropriately adult level). Were we to do this, I am convinced that we would induce a discontinuously sharp improvement in the understanding acquired by our students, eliminate the fear and hostility

that many hold toward science, and at the same time start producing what does not yet exist: a corps of school teachers competent to handle the elementary science materials.

### THE FAILURE OF VERBAL INSTRUCTION

As we look for improved effectiveness in college science teaching and for the sources of our failures, experience makes it increasingly clear that purely verbal presentations—lecturing at large groups of students who passively expect to absorb ideas that actually demand intense deductive and inductive mental activity coupled with personal observation and experience—leaves virtually nothing permanent or significant in the student mind. The procedures that have been found necessary to generate real learning in the elementary school child are equally necessary for the college student (if he has not yet had the given learning experience); hence the significance of the pedagogical patterns set by the new elementary science materials.

In the last few years I have had occasion to work with college students (many of them future elementary teachers) who come to take some physical science late in their academic careers. I find that all of these students have, somewhere in their school experience and elsewhere, heard the term "electrical circuit," seen diagrams of circuits in books or on blackboards, listened to descriptions of facts and concepts concerning current electricity.

When these students are given a dry cell, a length of wire, and a flashlight bulb and are asked to get the bulb lighted, they almost invariably start by connecting the wire across the terminals of the battery and holding the bottom of the bulb to one battery terminal. They have no sense of the two-endedness of either the battery or the bulb; few of them notice that the wire gets hot when connected across the battery terminals and almost none infer anything from the observation; it takes them up to twenty minutes to half an hour to discover, by trial and error, a configuration that lights the bulb. Seven-year-old children when confronted with this situation go through exactly the same sequence at the same pace. In the absence of the synthesis of actual experience into the concept of "electrical circuit," the college students, despite the words they "know" and the assertions

and descriptions they have heard, have no more understanding of the ideas involved than the seven year old approaching the phenomenon *de novo*. Purely verbal indoctrination has left essentially no trace of knowledge or understanding.

These results are confirmed repeatedly by my colleagues and can be documented over and over again with other illustrations. In having the same group of students carry out a very basic and unsophisticated investigation of the behavior of pendulums, I brought them to the point where they simultaneously started swinging two pendulums of equal length but unequal weight of bob. They were astounded that the pendulums swung together in synchronism despite the fact that one bob was of lead and the other of wood. When I asked whether they were aware of any other instances in which two very different bodies moved together if released simultaneously, a few students responded that they had "been told that such bodies would fall together if dropped from a window," but that they had "never really believed this." Purely verbal inculcation, uncoupled to experience and unrelated to any additional context or phenomenon, had left no trace of knowledge or understanding and had not even attained credibility, much less awareness or expectation of a connection between free fall and the swinging pendulum.

It is easy to get students to repeat the statement of a law or principle perfectly correctly. This is, however, no assurance that they have any understanding whatsoever of the principle being enunciated. Take, for example, Newton's first law of motion (the law of inertia): A body moves in a straight line at uniform velocity unless a force acts to change either the magnitude or direction of the velocity. This statement was the 17th century declaration of independence from Aristotelian science. An understanding of its implications is essential to the transition of each one of us from the Aristotelian view of motion with which we are born to the far less obvious view that lies at the heart of modern science. Without an understanding of this conception, one cannot begin to comprehend why we hold the view that the earth and planets revolve around the sun.

An understanding of Newton's first law resides not in the ability to repeat the words of the statement but in the ability to recognize its

relevance or applicability in simple, everyday phenomena. If the reader has never done so, I suggest that he take a group of students who have become verbally familiar with this principle, who can talk glibly about the frictionless puck moving at uniform velocity on a smooth tabletop, and ask them about the forces acting on the puck while it is midair, in a trajectory resulting from having sailed off the edge of the table. He will be shocked at how many of these students insist on the sudden appearance of a horizontal force in the direction of motion, a force they did not invoke while the puck was moving along the table. These students can give a correct statement of the law of inertia, but they have no real understanding of its meaning. The idea is subtle; it takes time to assimilate from a sufficiently wide context of laboratory experience and thought experiments, but students are rarely afforded this luxury; all too frequently they are expected to be purged of their natural Aristotelianism simply by listening to a lecture, working a few sterile, end-of-chapter examples (not problems) that contribute neither insight nor understanding, and then regurgitating the verbal statement memorized as Newton's first law.

If one gets students to think through the problem of the force exerted by the floor of an accelerating elevator on a person standing inside and carries the reasoning step by step in the direction of increasing the downward acceleration, he can lead them into a perception of what happens when the acceleration approaches that of free fall; the force exerted by the floor on the person becomes zero; all objects in the elevator are falling freely side by side; this is the condition referred to as "weightlessness." Then suggest the following thought experiment: Suppose the elevator cabin is now catapulted upward; it leaves the catapult, moving upward with decreasing velocity. During the period of upward motion, what will conditions in the cabin be like? What force will the floor of the cabin exert on the person inside? Relatively few students recognize that the situation is again one of weightlessness—in this sense, just another instance of free fall, even though the motion is directed upward.

Only after such questions have been raised and the thought experiments digested, do many of the students begin to recognize orbital motion of a

satellite or the coasting of a space ship toward the moon as additional instances of a condition of weightlessness, conceptually identical with those cited above. All this takes time, contemplation, freedom to think incorrectly and then retrace and adjust one's line of thought. Not given such an opportunity, students desperately try to memorize what the lecturer tells them about the end results. They gain nothing in knowledge and understanding. They see science as a mystery totally impenetrable to them and harden their feeling of hostility toward an enterprise whose irrelevance is magnified by exactly this impenetrability.

If you have students perform a simple experiment on the electrolysis of water, collecting oxygen and hydrogen in separate tubes, stop and ask them how much liquid water disappeared in order to form the gases in the tubes: Was it a volume of water equal to the volume now occupied by the gases? Was it more? Much more? Less? Much less?

Regardless of what has previously been said verbally about densities of liquids and gases, regardless of what calculations have been made in sterile, end-of-chapter numerical exercises, you will find that many students say that the volume of water used up was equal to the volume of gas formed. Few have noticed that the water level has risen in the surrounding container or by how much; and even if they have noticed, they have not thought to interpret the effect. A few leading questions can now send them back to some pencil and paper work with volumes and densities; the inquiry has become motivated by a challenge and a question related to experience. When, through their own calculations, they realize how tiny an amount of liquid water has been used up and begin to comprehend what was meant by all the talk about density differences, the astonishment on their faces is well worth seeing. It is a lucid demonstration to the teacher of how little knowledge or perception of connections among disparate events has penetrated from verbal indoctrination and how necessary both experience and time are to the development of genuine comprehension.

I have been drawing illustrations from very elementary levels of college instruction, but the same problems pervade more specialized levels. I

was recently asked to devise a question on atomic physics for a preliminary examination for first year graduate students. Seeking a question that would probe for understanding of some very simple and basic aspect of modern physics, I chose to present reproductions of the emission and absorption spectra of sodium vapor. Calling attention to the fact that those lines that were present in the absorption spectrum exactly matched corresponding emission lines but that many lines present in the emission spectrum were totally absent in the absorption spectrum, I asked how these facts were qualitatively explained by the quantum model of the atom. Out of fourteen students, one gave the simple and straightforward answer that, in the case of absorption, electrons would have to be raised from ground states and that only those lines corresponding to such transitions could be present; several students launched into elaborate, irrelevant quantum mechanical formalism, liberally sprinkled with inapplicable jargon about selection rules; the remainder made no attempt to answer. This dismal failure is not the fault of the victims of the examination; these were highly selected, bright and able students. It is the fault of a system that forced them into becoming equation grinding automatons who had never had the time to contemplate the *physics* into which the analytical techniques give us such deep and elegant insights.

#### UNDERSTANDING IDEAS VS MEMORIZING END RESULTS

Virtually any student can tell you, with an ingenuous smile, that the Earth is spherical and that it and the other planets revolve around the sun, but if you ask how he knows these assertions to be true, on what evidence we believe such statements, his smile turns to dismay and embarrassment—in all cases except, perhaps, for a very few physics majors. In terms of our vaunted goals for "higher education," do these students really hold any significant knowledge? Are they in any way better educated than their medieval counterparts who would have given what we now consider the "wrong" answer on exactly the same basis that modern students give the "correct" one—an end result received from authority? If we wish to do more than render lip service to ex-

cellence, if we are indeed serious about cultivating capacities to think and to understand, to have our students see science as a comprehensible product of imagination and intelligence rather than as an assembly of "facts" and names, it is absolutely essential that we give them a chance to follow the development or growth of several significant concepts and theories—to address themselves to the questions "How do we know . . .?" "Why do we believe . . .?" For example:

Why do we believe the earth revolves around the sun? In what context of concept and theory is this statement "true"?

Why do we believe that matter is discrete in structure; i.e., what is the evidence for the atomic-molecular theory?

What do we mean by the concept of "electrical charge"? How does the concept originate? Is "charge" a kind of substance? On what grounds do we believe there are only two kinds of electrical charge? What (hypothetical) experience would force us to conclude we had discovered a third variety?

Why do we believe that atoms themselves have discrete structure on a subatomic scale? What are some simple, intelligible pieces of evidence? (Bland assertion of the existence of an entity named "electron" is not evidence of anything at all; yet much teaching is done in this style.)

What experiences lead to and reinforce the creation of the concept of "electron"? What is the evidence that such an entity is a universal constituent of matter? What is the evidence that it has subatomic mass?

#### PACE AND UNDERSTANDING

If we are serious about cultivating some measure of the kind of understanding I have been defining above, we must give the students time to learn; the pace must be slow enough to let them confront evidence, to think and contemplate, to relive some of the steps by which the human mind first achieved these insights. This means we *must* cut down on "coverage." It is futile and fatuous to drown students in a stream of names and jargon, to throw at them in one quarter or one semester all of physics from Galilean kinematics to the un-

certainty principle, not to speak of adding meteorology and geology on the side. It is equally fatuous to submerge them in verbal assertion of the end results of chemistry or molecular biology as is so frequently done.

In a well meaning "science methods course" in a school of education, I have seen future elementary teachers reading a text which, among other things, discussed the nature of scientific law and theory, making correct but casual allusions to the "Copernican Revolution" and the "Newtonian Synthesis," to thermodynamics and the kinetic-molecular model. The same text discussed Piaget's investigation of conservation reasoning in children at different age levels and discussed concept formation and the way in which concepts, which we invent by acts of our own intelligence, give us an insight into deep relations among apparently unrelated phenomena. The students reading this text were the ones who shorted the battery and set the bulb on one terminal hoping against hope that it might light; they were completely innocent of any genuine scientific knowledge, having satisfied their "requirements" by memorizing names in "easy" science courses. They did not have the remotest conception what was meant by "Copernican Revolution" and "Newtonian Synthesis"; they had no idea of what "conservation reasoning" was; they could not give an example of a concept, much less point to a case in which a concept revealed deep relations among disparate phenomena.

These students dutifully read the text and tried to memorize words and phrases they might recognize on a multiple choice test. They had no idea that they had no understanding of what they were reading; all of their other "learning" experiences had been of the same variety, and they assumed that this was the way of all "knowledge."

When I tell fellow members of the scientific community about this travesty, many of them sneer patronizingly (or contemptuously) and ask me what else I would expect of the "educationists." Yet when I look at what these same scientists are doing in their own courses I find numerous examples such as the following:

Students are being told about the "fascinating" particles of high energy physics, with jargon about interactions, angular momen-

tum, mass-energy relations, quantum transitions, and the uncertainty principle, while they have yet achieved no conception of what is meant by velocity, acceleration, force, mass, energy, or electrical charge, much less of how we obtain evidence regarding the structure of matter on a scale that transcends our senses.

Students, who are still intrinsically Aristotelians and have no significant understanding of the law of inertia, are invited to toss around phraseology about Coriolis effects in meteorology and oceanography.

Students, who have no notion how to define "local noon," midnight, or the north-south direction, who have no idea of the origin of the seasons or the phases of the moon (they believe the unilluminated part of the moon to be the earth's shadow), who are unaware that the stars have a diurnal motion, are subjected to lectures on stellar nucleosynthesis, quasars, pulsars, and black holes in courses called "astronomy."

Students are conned into reading and talking about DNA, the molecular nature of genes, nerve and muscle action, while they have no idea why we believe in atoms and molecules; how we come to know anything about molecular formulas, size, or structure; what is meant operationally by "oxygen," "nitrogen," "carbon"; what is meant by "electrical charge" or "potential difference" and how we know that these concepts have anything to do with nerve action.

Among the students being debilitated in this way is a major fraction of our future elementary teachers. Is it any wonder they emerge totally unable to handle the new elementary science materials? Students exposed to such incomprehensible jargon and end results are being bludgeoned with a non-educational experience not one iota different from the debilitating one I described in the methods course—this time inflicted not by educationists but by scientists so wrapped up in their beautiful, up-to-date words, names, and insights that they have lost all awareness of how impenetrable the whole miasma is to a newcomer—how long it takes to develop some under-

standing of necessary prior concepts; to follow at least a plausible line of evidence, even if it is incomplete and not perfectly rigorous; to see at last what we know and how we know it.

When I urge, as I do here and continue to do at every turn, that we back off, slow up, "cover" less, give students a chance to think and understand, someone invariably demurs: "But if we stop way back here, if we do not cover our subject, the students will never *know* about this matter, or that, or the other which is so profoundly important, or which is so fascinating because it happens to be modern or topical!"

To this I can only respond that the demurrals constitutes a terrible prostitution of the word "know." What did the students reading the methods text "know" as a result of having read it and memorized the phrases? What do students coming out of the similar science instruction I have just described "know"? I submit that they "know" absolutely nothing; that the jargon they have acquired is not knowledge or understanding but is useless, irrelevant baggage that evaporates immediately after the course examination; that even when the jargon is remembered in bits and pieces, students cannot put it together into meaningful statements or insights of their own.

To the interested or doubtful reader I suggest the following experiment: Ask any group of students, including ones who have had a conventional introductory physics course, to write a one-page statement of what the term "electron" means to them—where the idea comes from, why we believe in such an entity, where and how electrons occur, and what properties they have. Virtually everyone has heard and used this term, but the papers, in the majority of cases, are either a string of meaningless gibberish with words juxtaposed in random sequence, or just a plaintive, more honest, confession of complete ignorance: "I was told that such things exist; I have no idea of what they are or how we know anything about them." Reading such papers is a traumatic but salutary experience; I urge others to share it with those of us who have tried the experiment. (I wish to make it clear that I am not objecting to exposing students to the concept of "electron." I only make the earnest plea that, if we elect to do so, we give the exposure sufficient time, breadth of context, and connection to relevant ideas and

experiences to make the concept meaningful in terms of the questions raised above—not just a meaningless verbal assertion.)

The time is long past that we can teach our students all the things they must know. It is hardly an original assertion that the only viable and realistic function of higher education is to put the students on their own intellectual feet: to give them conceptual starting points and an awareness of what it means to learn and understand something so that they might then continue to read, study, and learn, as need and opportunity arise, without perpetual formal instruction. Instead of just rendering lip service to this ideal, let us implement it by teaching science in an experimental, individualized way such that students have a chance to understand and master a limited number of important ideas instead of staggering breathless through a verbal marathon.

#### FACETS OF SCIENTIFIC THOUGHT

When in the *Two New Sciences*, Galileo confronts the problem of describing the change in the velocity of a moving body (the idea to which we give the name “acceleration”), he points out that there are at least two alternatives: (a) we observe that the object changes its velocity from one value to another while it traverses a distance of so many feet, and we might then elect to describe this motion by means of the number which indicates how much the velocity changes for each successive foot of displacement; (b) the same velocity change, however, occurs over a measurable interval of time, and one might also characterize the process by the number which indicates how much the velocity changes in each successive second. Which mode of description should be adopted? The choice is not trivial.

Galileo selects the second concept: change of velocity per unit time. His objective is to create a description of “naturally accelerated” motion (free fall), and he has a deep intuitive conviction that free fall is *uniformly* accelerated in this sense, but not in the sense of change of velocity per foot of displacement. On the basis of an hypothesis, an inductive guess, he selects the concept that will yield the simplest and most elegant description of free fall and proceeds to test the hypothesis by deducing consequences that can be tested by experiment.

Here are lucidly displayed several significant facets of the scientific enterprise: the roles of inductive and deductive reasoning; the fact that scientific concepts are created by acts of human intelligence and are not material objects stumbled over and described by their discoverer like a new continent or a new animal species; the fact that an element of choice may enter into the sequence and that there might be room for essentially aesthetic criteria such as elegance and simplicity.

I do not invoke this well known story to make a claim to new or profound insights into the philosophy and history of science. I only wish to point explicitly to a set of significant ideas that young college students can comprehend and appreciate—ideas that lie just below the surface in any introductory study of physical science but that students are rarely given the opportunity to discover, articulate, and savor. To discover these insights, students must have the opportunity to stand back and examine what happened, to relive some of the intellectual experience, to analyze and assess the line of thought, recognizing the elements of its logic, its strengths and its limitations.

In most texts and courses, however, students are not afforded this opportunity. The standard definitions of velocity and acceleration are asserted as though they were inevitable, rocklike formations that have existed for all time, while deference is paid to “history” by mention of the name of Galileo and by a few pompous, unsubstantiated clichés about his invention of “The Experimental Method” and his paternity with respect to “Modern Science.”

Students can indeed acquire mature and intelligent intellectual perspectives toward the methods, processes, successes, and limitations of science, but such perspectives are not automatically conveyed by training them to calculate how high a stone rises when it is thrown up into the air or how much an electron beam will be deflected by a given electrical field. The intellectual perspectives can be developed only by coupling conceptual understanding of the kind defined earlier in this paper to an articulate discussion of how the concepts or theories originate and evolve, how they are validated, what limitations they have exhibited, what connections they have revealed among apparently unrelated phenomena, what role they have played in social or intellectual

history and in our view of man's position in the universe.

#### FURTHER EXAMPLES OF HISTORICAL AND PHILOSOPHICAL IDEAS

Opportunities to examine these facets of the cultural phenomenon that is science literally abound at almost every turn as can be illustrated by a few specific examples:

From the didactic manner in which scientific concepts are forced on students in early schooling, it is understandable that they acquire the notion that scientific terms are rigid, unchanging entities with only one absolute significance that the initiated automatically "know" and that the breathless student must acquire in one brain-twisting gulp. It comes as a revelation and a profound relief to many young people if one introduces them very explicitly to the fact that scientific terms go through a sequence of evolution, redefinition, sharpening, and refinement as one starts at a crude, initial, intuitive level and, profiting from insights gained in successive applications, develops the concept to its later sophistication.

For example, the concept of "force" is legitimately introduced by connection with the primitive, intuitive, muscular sense of push or pull, but, in the law of inertia, we quickly redefine it to apply to *any* effect that imparts an acceleration to a material object (the action of an electrically charged rod on bits of paper). We endow completely inanimate objects with the capacity to exert forces on other objects [the charged rod exerting a force on the bits of paper, the table exerting an upward force on the book that rests upon it, the Earth exerting a downward force on us (our weight) and an upward force at our feet]. Following Newton, we then extend the concept even further and create the idea that when the table exerts an upward force on the book, the book simultaneously exerts a downward force on the table. By this time we have come a very long way indeed from the original use of the word "force" for an animate, muscular push or pull on another object.

Similarly, starting with the crude idea of "velocity" as a measure of how fast (as an average over a finite time interval) an object travels along a straight line, we refine this primitive notion into

a concept of *instantaneous* velocity; we endow the concept with additional properties of direction in space and with rate of change of both direction and magnitude.

At each stage in this sequence of evolution and redefinition, the same original word ("force" or "velocity" as the case may be) denotes a new and more sophisticated concept; its meaning has been changed in significant, intrinsic ways; it no longer denotes only the first intuitive idea to which it was applied. Modest self-consciousness about the process of definition and redefinition enormously increases the confidence of students in their own grasp of the new sequence of thought, opens their eyes to similar shifts and extensions in the subsequent generation of concepts such as "energy" and "electrical charge," and alerts them to watch for similar semantic shifts that are rarely pointed out to them in their study of social sciences and humanities.

During the 1830's and 1840's, Michael Faraday's beautiful and elegant experimental investigations of electricity and magnetism caused him to raise some very deep questions about these phenomena, and students can be led to articulate a few of these themselves: Is there a *process* by which one electrically charged particle exerts a force on another? If one of the particles is suddenly displaced, does a finite time interval elapse before the force on the second changes? Does a finite time interval also elapse between the instant an electric current flows in a wire and the instant a neighboring compass needle begins to swing in response to the magnetic effect of this current? If a finite time interval does elapse in each case, what happens in the intervening space between the interacting objects? To answer these questions, Faraday invented a model, a visualization that completely transcended any direct sense experience—the famous concept of "lines of force" that stretched, contracted, spread apart, and pulled together, propagating electric and magnetic effects through evacuated space—the concept that Clerk Maxwell subsequently elaborated into the sophisticated modern notion of "field." Almost apologetically, Faraday writes about his highly speculative model:

It is not to be supposed for a moment that speculations of this kind are useless or



necessarily hurtful in natural philosophy. They should ever be held as doubtful and liable to error and to change, but they are wonderful aids in the hands of the experimentalist and mathematician; for not only are they useful in rendering the vague idea more clear for the time, giving it something like a definite shape, that it may be submitted to experiment and calculation; but they lead on by deduction and correction, to the discovery of new phenomena, and so cause an increase and advance of real physical truth, which unlike the hypothesis that led to it, becomes fundamental knowledge not subject to change.

Not only is this a beautiful description of the point and function of a theoretical model, but it simultaneously reveals a characteristic facet of the thinking of many nineteenth century scientists: They were indeed convinced that they were stockpiling "real physical truth" and "knowledge not subject to change."

After the students learn something of the conceptual revolution associated with the elements of relativity or after they have seen some of the failures of Newtonian and Maxwellian physics in the atomic realm, it is interesting to ask them to contrast with Faraday's statement the sadder and wiser one by Oppenheimer:

We come to our new problem full of old ideas and old words, not only the inevitable words of daily life, but those which experience has shown fruitful over the years.... We love the old words, the old imagery, and the old analogies, and we keep them for more and more unfamiliar and more and more unrecognizable things.

In the light of such perspectives, students spontaneously begin to articulate some sense of why most scientists now view scientific knowledge as mutable and provisional rather than permanent and final. They anticipate limited ranges of validity to successful theories and are fully prepared to find a deeper regression of unanswered questions behind every answered question.

In still another sequence involving models that transcend direct sense experience, one can get

students to follow and examine the evidence that led to our belief in the atomic-molecular structure of matter as well as in a structure of atoms themselves. They must be allowed to doubt with the early participants, to articulate uneasiness about the interpretation of some of the evidence—not just to be stuffed with a few disconnected and, in themselves, unconvincing arguments, followed by assertion of the end results. (After all, the original doubters were a goodly and far from foolish company.) Many illustrative gems line the way through such a sequence. Dalton, for example, in his original attempts to develop a quantitative atomic-molecular theory confronted chemical data in the form of percentage composition by weight of various compounds. The only regularity that had been noted in these data was the so-called "law of definite proportions"—the fixed percentage composition of any definite chemical compound, and even this was still a matter of some controversy and uncertainty.

Dalton's preconceptions concerning corpuscular constitution of matter led him to give particular consideration to cases in which a given pair of elements (say carbon and oxygen) form more than one compound, and it occurred to him that if 1.0 g of carbon combines with 1.3 g of oxygen in one compound then for the same 1.0 g of carbon in the other compound one should find perhaps 2.6 or 0.65 or 3.9 g of oxygen—or some other quantity that bore a small whole number ratio to 1.3. One would expect just such simple numerical relations if compounds did indeed consist of molecules made up of small numbers of atoms of the combining elements. The data had never been examined this way; this particular orderliness lay hidden behind the unrevealing percentage compositions. Dalton looked, and the order was there; he *predicted* what is now glibly known as the "law of multiple proportions." (In most modern courses this law is presented as though it had been known initially and provided *a priori* evidence for the atomic theory.) The point here, of course, is that very frequently "facts" do not speak for themselves. In this instance the facts had been available for a long time, but they were not even seen until looked for through the lenses of a theory; then suddenly their presence fed back as a dramatic confirmation of the theoretical conception that revealed them.



An inverse illustration of this idea resides in the story of the famous Piltdown hoax which was exposed in the 1950's. Many paleontologists accepted the spurious "Piltdown Man" fossil with a man-like skull and an ape-like jaw because their theoretical preconceptions led them to expect an evolutionary sequence in which brain development led the way and changes in other parts of the body followed. They accepted the forgery for almost forty years, even though it was well known that it did not fit any known niche in the humanoid fossil sequence. Here again facts did not speak for themselves; they were viewed through the lenses of a theory, and the theory led many astray.

Very few students have any conception of the revolutionary thrust of seventeenth century science: the discarding of the notion that the heavens and heavenly bodies were made of a different substance and obeyed different natural laws from those of the terrestrial sphere; the subsumption of the entire universe under one system of humanly comprehensible natural law; the extension of the universe to infinity and the concomitant removal of the literal, sheltering heaven from close overhead. Here was a profound turning point in our intellectual history; the personal outlook of every individual toward himself and toward his place in the universe is deeply conditioned by this heritage from Galileo, Newton, and the other seventeenth century natural philosophers. An educated man should be aware of such a heritage in historical and intellectual terms, not in the mere assertion of end results. (Gerald Holton<sup>6</sup> gives a fine development of this episode in the history of ideas and an excellent version is contained in the Project Physics<sup>7</sup> materials.)

A similar revolution in intellectual history is associated with Man's growing awareness of mutability in the heavens, in the earth, and finally in living species—his grasp of the extent of geological time which so vastly transcends his own temporal experience. Through what groping, what steps, what transitions were the insights won? How do we come to hold the view of evolutionary processes that we now hold? There are fine educational experiences to be gained in following at least some of the pieces of this story, particularly as they are traced in works such as John C. Green's *The Death of Adam*.<sup>8</sup>

## VARIATIONS ON THE THEME

The preceding illustrations of epistemological, philosophical, and historical aspects of science happen to be personal favorites of mine; I present them for the purpose of being specific in my illustrations and not to advocate them above the host of other possibilities. Each teacher must select ones that appeal to him and that he can articulate to students in the most stimulating and compelling way. There is the whole array of aspects that James Conant referred to as the "tactics and strategy of science." There is the fascinating, partly scientific, partly sociological, problem of validation and acceptance of scientific theories. There are the philosophical problems of positivism and the questions concerning the "reality" of entities that transcend our senses: atoms, molecules, electrons.

There are also, of course, the topical, pressing, social problems that stem from the release of nuclear energy; the application of science to warfare; the possibility of synthesizing living matter and of controlling the genetic development of human beings; the problems of controlling and limiting abuse of our terrestrial environment. I have no intention of minimizing the significance of these vital problems, but I do have reservations about launching into analyses or discussions of them on a level not significantly different from that which I objected to in another context earlier in the paper: that of encouraging students to be glib with words such as "strange particles," "accelerators," "mass-energy relation," "atomic structure," and "uncertainty principle" while they have no idea of what any of these words mean, much less have any significant comprehension of force, mass, energy, gravity, or electrical charge. I see the two contexts to be quite analogous. If one takes the trouble to lay an adequate background for intelligent, critical discussion, a look at the problems mentioned above is fair game; otherwise, it is nothing more than trivial, superficial chitchat which does the damage of allowing students to think they have mastered profound levels of knowledge.

It is necessary to give students an adequate frame of reference, and that means it is essential to study enough of the relevant substantive scientific subject matter to make such discourse

and discussion meaningful. This does not mean that it is necessary to follow every historical dead end in exhausting detail, nor is it necessary to become involved in mathematical analysis that is excessively formidable and time consuming, especially for nonscience students. Each teacher must seek an optimum balance that will vary with the particular group of students addressed; they should be exposed to enough scientific subject matter to make their involvement genuine but not so much as to bury them. The essential criterion is that they must not end up regurgitating secondhand pronouncements about the nature and processes of the scientific enterprise without ever having articulated any such insights out of their own intellectual experience. Without at least some participation in comprehension and interpretation of scientific concepts, theories, and philosophy, secondhand statements about science have no more educational value than a commentary on poetry without a reading of the poetry, or a dissertation on the philosophy of history barren of any knowledge of the history of anything.

I have never known a colleague who had the temerity to offer a course under the rubric "Wisdom 402. 3 lectures, 1 laboratory session per week." Yet we all aspire to contribute to the wisdom of the human beings we strive to educate. We do so by dealing with rather modest and tractable elements of knowledge and insight that constitute our intellectual heritage and matrix of current inquiry. Rather than step into a classroom and beat our breast about the quandaries into which the release of nuclear energy has precipitated mankind, rather than pontificate about the still undefined ethical and moral problems that will descend on us with synthesis of living matter and control of genetic mechanisms, it seems to me far more effective and rational to get our students to confront science through some of the more modest insights and experiences I have tried to illustrate above. I am convinced that such studies contribute to the development of better educated men and more intelligent citizens in exactly the same way as do an awareness of history and sensibility to literature. As educated human beings they must then, together with all the rest of us, confront the grave problems that are not yet material for the classroom.

## WAYS AND MEANS

There is neither space nor time for a lengthy discourse on the logistics of teaching in the vein advocated in this essay; my intent is only to inject a few cursory remarks on what seem to me to be particularly crucial matters.

I cannot conceive of a truly effective science course that does not contain a tightly integrated laboratory experience as a vital and intrinsic component. This is not to imply, however, that the rigidly structured, step-by-step directed, *ex post facto* tests and "verifications" so prevalent in many existing laboratory courses constitute an educationally viable structure. These are almost invariably reduced to sterile busy-work that further antagonizes students and reinforces their sense of the artificiality and irrelevance of the effort required of them.

A viable laboratory is one in which the student must make some decisions of his own, profit from his mistakes, and retrace his steps if necessary. It must be one that allows the student to carry over his activities from day to day and does not compel him to "finish something" within the confines of a straightjacket. It must be one designed to generate learning by induction from experience rather than from *a priori* verbal indoctrination.

For prototype examples of laboratory work of this kind, I suggest referring to the elementary science materials cited earlier<sup>3-5</sup> and to the *College Introductory Physical Science Course*.<sup>9</sup> (There is also a voluminous and useful literature on college laboratory work to be found in the various journals devoted to problems of teaching physics, chemistry, biology, etc. Useful documents emanate from the Commission on College Physics, the Commission on Undergraduate Education in the Biological Sciences, and other such groups; the reader is urged to refer to the appropriate organs in his own field of science.)

Laboratory work is admittedly costly in space, time, and facilities. Some cost conscious administrators are pressing science teachers to abandon laboratory work (basing their pressure on legitimate criticism of the sterile laboratory instruction so prevalent in our colleges and universities) and to concentrate on lecture presentations to huge classes. This pressure should

be articulately and vigorously resisted if we still wish to strive for any measure of excellence and effectiveness in science teaching, but the resistance must be accompanied by cultivation of stimulating and effective laboratory experiences such as those I have attempted to define above. Much current practice is simply indefensible; attempts to maintain it without drastic change are probably doomed to defeat; and such defeat is bound to have a weakening impact on support of good instruction wherever it may be struggling for survival.

I urge teachers to experiment more widely and more courageously with individualized, open schedule, laboratory-oriented science courses, in which most of the work takes place in the laboratory from day to day, and in which lecturing is limited to occasional pulling together of concepts and subject matter *after* students have encountered them in laboratory experience and to the discussion of historical, philosophical, and sociological ideas *after* the students have learned enough subject matter to make the discussion meaningful. In other words, the verbal presentations and analyses, if they are needed, should come *a posteriori* and not *a priori*.

### TESTS AND PROBLEMS

One of the weakest links in our chain of instruction consists of the questions and exercises that are embalmed at the ends of chapters, purportedly to guide students in thought and study. Although there do exist a few texts that maintain a high intellectual standard, the great majority (particularly introductory texts for non-majors) confront the student with little more than debilitating chaff—chaff for which he has no respect and to which he has no motivation to respond.

The “problems” consist of routine drill in calculations, vocabulary, or identification (such drill is indeed necessary but, with a little more ingenuity, can be incorporated in broader and more interesting context), or they consist of sterile demands that the student calculate some final resulting value of a particular parameter under conditions in which all other relevant parameters have been preselected and specified. In other cases, eager authors have generated rather more interesting problems, but, wittingly or unwittingly, they have written for the eyes of

their colleagues rather than for students, and the results are problems far beyond the readiness or immediate comprehension of the students being addressed.

We are desperately in need of collections of questions and problems that, sensitive to the obstacles that arise in student minds, lead the student through the difficulties and subtleties in thinking and reasoning that he must face and overcome. We need questions that challenge his curiosity and ability to perceive relationships but that he can encompass and deal with successfully a reasonable fraction of the time. We need problems that lead him to make his own choices of relevant parameters, simplifying assumptions, or boundary conditions. We need problems that lead him into exploring extreme, special, or asymptotic cases in order to test his own reasoning for internal consistency. We must cultivate his habit of testing and checking the results of his reasoning in every possible way, so as to sharpen his own sense of when he is right or wrong and lessen his childlike dependence on confirmation from the teacher. Above all, we need questions and problems that, gently and gradually, lead the student into extending, inventing, perceiving questions of his own. This is, of course, the highest and most sophisticated skill, but it is quite possible to initiate such activity at very humble and unsophisticated levels and to see students develop steadily and rewardingly as they gain confidence in their own intellects.

Few aspects of a course do more to set its tone, cultivate the respect or contempt of students, and determine its overall effectiveness and reputation than do the tests and term paper requirements. It is essential that our testing be consistent with the educational principles we articulate. If we render lip service to reasoning, thinking, and understanding relationships, but then concentrate our test questions on memorizable end results, names, or procedures, we might as well forget the gradiose objectives. The students, just as human as all the rest of us, will concentrate on the memorizable end results and forego the “intolerable labor of thought, that most distasteful of all our activities”—to borrow Justice Learned Hand’s phrases.

Writing good tests and fruitful term paper assignments is a demanding, challenging, brain-

twisting chore, but when it is well and conscientiously done, it wins the respect and confidence of students and becomes one of the firmest underpinnings of a viable and successful course.

## LARGE COURSES

After discussion of the educational modes I have fervently advocated in this essay, I am frequently asked, "But what would you do if you have to teach science by lecturing three hours per week for one quarter to a class of five hundred?" Although my emotions respond with "a plague on all their houses," my intellect knows this to be a legitimate question. I can only say that no one—least of all I—possesses a magic wand with which to turn this pumpkin into a royal coach. This view *must* be firmly and repeatedly conveyed to presidents, deans, curriculum committees, trustees, legislators—any and all who influence policy, educational and financial. Unavoidable concessions will be made to expediency (the individual teacher cannot fight this alone), but the institutional authorities must not remain unchallenged when they simultaneously make specious claims about excellence of instruction.

What might one do in this case? I would proceed to lecture, taking a very limited number of topics or concepts; go very slowly, limiting the pace to that which students set themselves in an individualized course, with many illustrative questions and problems, discussed after students

have had a chance to think about them; use many demonstrations (not spectacular show pieces, but the simple fundamental experiences, deeply relevant to concept formation, that I would have used in the laboratory); use as many "take home" or "do at home" observations and experiments as I could contrive. If the course is enthusiastically and carefully done, with stimulating articulation of humanistic insights beyond the scientific content itself, I think it can be useful and respectable, but its effectiveness should not be overrated.

In summary, I make a plea for literate, sensibly paced, experience-oriented, courses of study that are firm and challenging in asking students to shape up to high standards of comprehension of concepts, soundness of reasoning, and clarity of expression in their mother tongue—courses that, by virtue of these very requirements, show respect for the intellect and capacity of the students.

(N.B. It is clear that throughout this essay I have been writing as a physicist. I can only ask the indulgence of non-physicist readers. My aim has been to provide very specific illustrations to back my contentions and advocacy; these illustrations, to be vivid and meaningful, had to come from personal experience. I am deeply convinced, however, that what I have had to say applies to virtually all college science teaching. Readers will certainly be able to connect their own analogous experiences with mine and extrapolate relevant aspects of this commentary to their own fields.)

<sup>1</sup> A. Etzioni, *Science* 177, 391 (1972).

<sup>2</sup> H. J. Muller, *The Children of Frankenstein: A Primer on Modern Technology and Human Values* (Indiana U.P., Bloomington, Ind., 1970).

<sup>3</sup> Educational Development Center, *Elementary Science Study* (Webster Division, McGraw-Hill, St. Louis, Mo., 1968).

<sup>4</sup> AAAS Commission on Science Education, *Science—A Process Approach*. (Xerox Education Div., Cambridge, Mass., 1968).

<sup>5</sup> Science Curriculum Improvement Study, *SCIS Materials* (Rand-McNally, Chicago, Ill., 1968).

<sup>6</sup> G. Holton, *Introduction to Concepts and Theories in Physical Science* (Addison-Wesley, Reading, Mass., 1952).

<sup>7</sup> Harvard Project Physics, *The Project Physics Text* (Holt, Rinehart, and Winston, New York, 1970).

<sup>8</sup> J. C. Greene, *The Death of Adam* (Iowa State U. P., Ames, Iowa, 1959; Mentor Book, New York, 1961).

<sup>9</sup> IPS Group of Educational Development Center, *College Introductory Physical Science* (Prentice-Hall, Englewood Cliffs, N.J., 1969).

## Addendum to "Toward Wider Public Understanding of Science"

ARNOLD B. ARONS  
Department of Physics  
University of Washington  
Seattle, Washington 98195

(Received 26 July 1973; revised 7 September 1973)

My recent article with the above title<sup>1</sup> has elicited a number of responses, and several of these independently focus on the same two themes: (1) that many college teachers do not bring to their grasp of the nature and origin of physical concepts the basic understanding necessary for the kind of instruction I advocate, and (2) that many students are intent on reaching immediately for modern, "exciting," topical ideas of science and its societal impact and are unwilling to devote the intellectual effort necessary to comprehend ideas underlying, or preceding, the ones in which they are "interested."

These are nontrivial questions regarding the validity of positions advocated in my article, and I would value the opportunity to respond to them.

I am not as pessimistic as my correspondents seem to be about the teaching capacity of our colleagues: I am deeply convinced that a statistically significant improvement would occur if more of us learned to listen to our students.

Most teachers are infuriated at any suggestion that perhaps they do not really talk with or listen to their students. Yet Mary Budd Rowe's<sup>2</sup> empirical investigations have shown that the average elapsed time between the teacher's posing a question and propounding an answer to the still-silent student is about 0.5 sec. Dr. Rowe adduces evidence for an optimum "wait time" of at least 4-5 sec—an interval that seems like all eternity to the waiting teacher. Given a little time, the student begins to think and then respond in propositional statements. Only under such circumstances is one talking with, and listening to, his students.

If a teacher disciplines himself to conduct such Socratic dialogs (giving nothing away and leading a student step-by-step out of confusion into in-

sight and comprehension), he begins to see the difficulties, misconceptions, verbal pitfalls, and conceptual problems encountered by the learner.

Our own learning of the science is so far back in our personal histories and so smoothed by our facility with such material that we have no capacity to anticipate the perfectly plausible, unstubid difficulties encountered by most students. By *listening* to what they say in answer to carefully phrased, leading questions, we can begin to understand what does and does not happen in their minds, anticipate the hurdles they encounter, and provide the kind of help needed to master a concept or line of reasoning without simply "telling them the answer."

Our *a priori* assumptions about the difficulties encountered by the learner tend to be unfounded and invalid. Nothing is more ineffectually arrogant than the widely found teacher attitude that "all you have to do is say it *my way*, and no one within hearing can fail to understand it."

When one starts *listening* to the students and leading them to explanations formed in their own words (instead of thrusting his own "lucid" explanations at them), he finds himself restructuring, rethinking, and relearning the physics he thought he knew so thoroughly. He acquires deeply rewarding new insights into his science and becomes increasingly sensitive to how we devise and why we believe the various conceptual structures we are teaching.

This increased sensitivity can be transferred so as to effect very substantial improvement in the teaching of larger courses where one cannot hope to conduct Socratic dialogs with any substantial fraction of the students. Thus the dialogs are profoundly important to one's development as a teacher even if they are not a feasible mechanism for the bulk of his teaching.

In my own case, I have acquired in this empirical fashion virtually everything I know about the learning difficulties encountered by the students. I have never been bright enough or clairvoyant enough to see the more subtle and significant learning hurdles *a priori*.

Were more of us willing to relearn our physics through the dialog and listening process I have

described, we would see a discontinuous upward shift in the quality of physics teaching. I am satisfied that this is fully within the *competence* of our colleagues; the question is one of humility and desire.

With respect to the second point raised by my correspondents, I can only say that I myself have never had the kind of trouble they describe. It seems to me that troubles with this attitude arise only when a teacher does not really have the courage of conviction and all too readily surrenders to a specious demand.

For those students who come with an articulate interest in "modern" theories or in ethical and social problems, I see nothing wrong in starting with a look at the problems that have initially engaged their interest. As one makes entry into these problems, however, and finds concepts and ideas that are not understood, he should make the relevance of the latter compellingly clear and show the students that intellectual honesty requires going back to the necessary fundamentals. Otherwise one succumbs to unnecessary superficiality and dilettantism. In my experience, students have been receptive and cooperative; they do *not* stubbornly insist on superficial chit-chat once they see where intellectual integrity lies.

As for students such as the future elementary teachers I have been working with in recent years and whose learning experiences I cite in my article, they are so captivated by the opportunity to understand—for the first time in their lives—something about floating and sinking, about the motions in the sky, the behavior of the moon, the seasons of the year, why we believe in atoms and molecules, how we visualize processes in the microscopic world that transcends our senses, and how we form the model of "electric current," that it never occurs to them to demand immediate disquisitions on relativity, quantum mechanics, stellar nucleosynthesis, pollution, or energy crises. Furthermore, when the opportunity to understand the scientific concepts is coupled with historical and humanistic perspectives such as those described in my article, when they begin to say on their own initiative that the insights we are cultivating apply to all the subjects they will have to teach, they are very far indeed from the attitudes my correspondents are worried about.

<sup>1</sup> A. B. Arons, *Am. J. Phys.* **41**, 769 (1973).

<sup>2</sup> Mary Budd Rowe, *Science, Silence, and Sanctions*, *Sci. and Children* **6**, 6 (March 1969). Also: *Teaching Science as Continuous Inquiry* (McGraw-Hill, New York, 1973), pp. 240 ff.



## Introduction, Part II

### Structure and Content of the Course

This course is designed as part of a general education curriculum for non-science majors having little or no prior background in mathematics or the physical sciences. It is also intended to provide a subject matter base for both preservice and inservice elementary school teachers, and the content is deliberately selected to cut across substantial segments of physical science subject matter common to the major new elementary school curricula. (See, for example, references 3, 4, 5 in the preceding article "Toward Wider Public Understanding of Science.") The text material reflects several years of experience with each of these three student populations, and coverage has been restricted in accordance with the principles advocated in the preceding article.

The course begins with two separate lines of study pursued simultaneously. One line, comprising Chapters 1, 6, and 11 (Units A through D), concentrates on naked-eye astronomy and formation of both the geocentric and heliocentric models of the solar system with emphasis on recognizing that naked-eye observations cannot discriminate between the two models. The second line (Chapters 2 - 10, excluding Chapter 6) concentrates on development of concepts such as "property," "substance," and "conservation of mass," builds up evidence supporting the view that the structure of matter might be regarded as discrete rather than continuous, and leads to formation of the atomic-molecular model.

Beginning with Chapter 12, attention turns to the Galilean description of motion, the law of inertia, and a non-mathematical development of Newtonian dynamics centered around a qualitative but extensive use of the concept of force. As the concepts of kinematics and dynamics are formed from laboratory experiences, they are repeatedly applied to phenomena observed outside the laboratory and are also extended: (a) to the microscopic domain through addition of kinetic conceptions to the atomic-molecular theory, and (b) to the solar system in laying the basis for the triumph of the heliocentric model.

Beyond this point, the text continues with chapters on wave motion and optical phenomena. An inquiry-oriented exploration of electrostatics and magnetism could be inserted in place of some of the material on wave phenomena or light, but the latter subjects have not been included in the text in order to restrict its length. The author would be happy to supply single copies of chapters on electrostatics and magnetism to individuals who request them.

Obvious missing ingredients are the energy concepts and conservation of energy. No one regrets this hiatus more than the author. It was impossible, however, to include the material and remain consistent with the basic philosophy concerning allowance of time for development of conceptual understanding advocated in the preceding essay. A start on formation of energy concepts is made at the end of Chapter 5 on Thermal Phenomena. Teachers wishing to pursue this line while omitting other portions of the text will find that the development of energy concepts

3842  
14 13.87  
Phu bin

in Physical Science II\* merges very smoothly with these text materials in conceptual point of view and in pedagogical format and attitude.

At the University of Washington this text is used in a full-year course. Students must complete two quarters to receive credit; the third quarter is optional. The course is scheduled for a total of five hours per week: three one-hour and one two-hour sessions. Were the enrollment to exceed 80, the course would be given on an open-laboratory rather than a scheduled-hour basis.

The text is intrinsically designed for a PSI (personalized system of instruction) or "Keller Plan" format. We have found it best, however, if students work in pairs rather than individually. Many of the experiments go more smoothly if more than one pair of hands is available, and much more effective learning takes place when students argue, discuss, explain, and help each other with the questions and problems interspersed in the body of the text as well as those organized to provide synthesis at ends of chapters. These questions and problems are not simply drills or exercises; they are, in effect, study guides to the level of understanding which is the underlying objective of the entire course. As the course proceeds the amount of detailed explanation and didactic presentation in the text is deliberately decreased and is replaced by socratic questioning intended to direct the student toward exploration, investigation, and the taking of larger steps in forming his own inferences and conclusions. Few students have the capacity to penetrate and grasp such material by working entirely alone. Dialogs with fellow students and staff members are essential to the development of understanding and the retention of what is learned.

With respect to the PSI format each chapter constitutes one unit. (In a few special cases there are two units in a chapter.) A very brief study guide and a fairly detailed statement of learning objectives are placed at the end of each chapter. It is left up to individual teachers to expand or reform the study guide sections in whatever way better suits their own programs. In many instances the units can be shortened by omitting sections of the chapter and also omitting some of the end-of-chapter problems. Such directions could be incorporated in an altered study guide.

This handbook contains many of the questions we have found effective as end-of-unit check-outs or competency tests. Since the sophisticated grasp and level of understanding sought in this course cannot possibly be "mastered" on a first passage through the material, it is unwise to attach the frequently used label "mastery learning" to this framework and to force students to repeat tests on a unit until they attain some arbitrary grade level such as 90%. It is better to let students proceed to the next unit as long as they show enough grasp to justify taking the next step. The text is so structured that the student is continually spiralling back and re-using earlier concepts, models, and lines of reasoning in new and increasingly rich contexts. It is this continual re-cycling which will help insure growing understanding and retention more effectively than would insistence on a fictitious unit-by-unit "mastery".

---

\* Physical Science Group. Physical Science II. Prentice-Hall, Inc., Englewood Cliffs, N.J. (1972)



Although principally intended for a laboratory-oriented PSI format, it should be quite possible to use this text in a classroom - lecture framework. In this case, the instructor will find it necessary to treat as lecture demonstrations many of the experiments prescribed in the body of the text and to re-design others as take-home experiments.

In either format, the astronomy material of Chapters 1, 6, and 11 is meant to be spread out over several months, with observations being accumulated outside of class time. In our operation, occasional discussion sessions are held and questions are included on tests and examinations in order to keep the students working on the material, but class time is devoted almost entirely to the sequence on the structure of matter.

Instructors acquainted with the theory of intellectual development of Jean Piaget and his co-workers\* will discern elements of a Piagetian orientation in this text. It has been our experience that the great majority of students (including in-service elementary teachers) have not developed the capacity for formal operational reasoning at the time they enter the course. Thus the text has been designed to incorporate numerous and repeated exercises in formal thought: recognizing and controlling variables, doing syllogistic reasoning, discriminating between observations and inferences, recognizing inadequacy of information or evidence, translating words into symbols and symbols into words, forming models by inductive reasoning and drawing deductive inferences from the models, doing hypothetico-deductive reasoning, doing arithmetical reasoning — particularly that involving division or proportions.

We find that, given the repetitions and re-cycling incorporated in the text materials and given unrelenting insistence on the expectations defined by the text and examination questions, the great majority of students show significant progress toward formal operations by the end of the second quarter\*\*.

Additional discussion of teaching and learning problems, suggestions derived from our own experience, and miscellaneous details applicable to each individual unit will be found in the following sections of the handbook.

---

\* See, for example, B. Inhelder and J. Piaget. *The Growth of Logical Thinking*. Basic Books 1958.

\*\* For more details concerning the attempt to enhance intellectual development, see A. B. Arons. *Cultivating the Capacity for Formal Reasoning: Objectives and Procedures in an Introductory Physical Science Course*. *American Journal of Physics*. September 1976.

## Introduction, Part III

### Laboratory Apparatus and Supplies

The laboratory work in Chapters 2, 3, 4, 5, 7, 8 and 10 draws heavily on experiments devised for "Introductory Physical Science" by the IPS Group of the Educational Development Center. Versions of this course have appeared in the following forms:

Introductory Physical Science. First Edition, IPS Group, Education Development Center. Prentice-Hall, Inc., Englewood Cliffs, N.J. 1967

Introductory Physical Science. Second Edition. U. Haber-Schaim, J. B. Cross, G. L. Abegg, J. H. Dodge, J. A. Walter, Prentice-Hall, Inc. 1972

College Introductory Physical Science. IPS Group, Education Development Center. Prentice-Hall, Inc. 1969

The college version (CIPS) is out of print and has (as of 1976) been replaced by

Elementary Chemistry -- An Experimental Approach. Physical Science Group, Boston University. Published by Physical Science Group. 1974.

Much of the equipment and supplies can be improvised from standard chemical laboratory stock and common physics apparatus. The specific items illustrated in this text, however, are all available from

Educational Book Division, Prentice-Hall, Inc. Englewood Cliffs, N.J. 07632

and are listed in their "Science Catalog." One can purchase individual items as required or complete IPS kits for classes of 24 or 30 students. The complete IPS kits contain materials for the experiments utilized in this course, but they also include materials for other IPS experiments not being utilized herein.

Chapters 1, 6 and 11 deal with naked-eye astronomy and, for the most part, utilize equipment readily improvised at home and around the laboratory. Photographs of arrangements suggested for elementary school use will be found in the teachers' pamphlets for "Daytime Astronomy" and "Where is the Moon?" from

Elementary Science Study. Webster Division, McGraw-Hill Book Co., St. Louis, Mo.

The only piece of equipment not readily improvised is the transparent Celestial Globe suggested in Chapter 6.

The equipment for Chapter 9 "Batteries and Bulbs" can be assembled from local sources or can be purchased as a complete kit from among the Elementary Science Study materials.

From Chapter 12 onward, the experiments utilize physics equipment available from most of the regular scientific supply houses. Courses which utilize some of the same equipment are

The Project Physics Course. First Edition 1970 , Second Edition 1975. Holt, Rinehart and Winston, Box 3323 Grand Central Station, New York, N.Y. 10017.

Project Physics equipment is supplied by Damon / Educational Division, 80 Wilson Way, Westwood, MA 02090.

PSSC Physics. Third Edition, 1971. D. C. Heath and Co., Lexington, Mass.

Since most instructors will probably wish to be selective about the chapters and experiments they utilize, a complete list of apparatus and supplies has not been assembled in this section. Comments on sources and utilization of equipment are given for each experiment, chapter by chapter, in the following sections of the Handbook.

## Chapter 1

### Familiar Statements, Large Questions

#### 1.1 Teaching Unit A

To emphasize the experimental, hands-on orientation of this course, it has been our procedure to launch the students on Weighing and Balancing in the Unit 1 study guide (end of Chapter 2) immediately on the first day of class. They read Chapter 1 at home, and work along in Chapter 2 as they proceed through Unit 1.

Unit A, the first unit on astronomy, has, for convenience, been inserted at the end of Chapter 1. This is a self-study unit with no specifically associated text materials. The idea is to have the students accumulate their own naked-eye observations of the most basic celestial phenomena instead of vicariously repeating verbal assertions culled from texts. The observations called for are quite closely parallel to those structured into the elementary school units "Daytime Astronomy" and "Where is the Moon?" of the Elementary Science Study (ESS) curriculum.\*

The observations involved in Unit A must, for the most part, be made outside of class time, and the students should be launched on these observations immediately. A useful device is to set up "committees" that correlate their work within the committee and periodically report to the rest of the class; e.g. a committee on sunrise composed of those who reside where they can readily see the eastern horizon, etc.

It is recommended that a minimum of class time be spent on Unit A. An occasional very brief interim discussion or report of a committee is desirable in order to keep the activity in view and remind the students that it is to be sustained, but additional investment of class time is unnecessary and undesirable. It is very desirable, however, to post accumulating results from time to time: someone's sketch of the shift of position of sunset, a record of the shadow of the vertical stick on some particular day, a short sequence of lunar change with dates, times, and approximate angle between moon and sun.

Unit A, as presented, is quite lengthy and could conceivably be broken up into smaller units. This should be done with discretion, however, because the questions in Section III are designed to weave the observations into a fairly coherent whole.

It is probably unwise to push the students toward rigorous, modern astronomical concepts and definitions in connection with Unit A. The whole point resides in developing crude, first-order definitions of geographical directions, zenith point, noon and midnight, etc., very much as the ancients might have done. It is important to have the students develop the feeling that they could, in principle, have accomplished the entire sequence themselves.

---

\* Educational Development Center. Elementary Science Study. Webster Division, McGraw - Hill Book Co., St. Louis, MO, 1968

In dealing with the observations and concepts developed in Unit A it is useful to keep in mind the fact that a large proportion of the students (not 100%, but a very major fraction in some groups) are unaware of matters such as the following:

that the positions of rising and setting as well as the elevation of the sun at noon change with time;

that the sun is never to be observed to pass "directly overhead" anywhere in the continental United States;

that the stars have a diurnal motion and are not simply fixed spots of light that appear after sunset;

that the moon also has a diurnal motion;

that the moon can be seen in daytime very frequently;

that the unilluminated portion of the moon is not the shadow of the earth;

that one never sees a star within the lunar crescent, i.e. against the unilluminated portion.

An awareness of these widely prevalent errors and misconceptions can be very helpful in guiding student inquiry and discussion and in comprehending the origin of some of the (seemingly) strange things that some of them will say.

Concepts such as celestial and terrestrial poles, local celestial and terrestrial meridian, terrestrial latitude, etc. might be developed in connection with Unit A if they arise naturally and spontaneously but it is not recommended that they be pressed. These ideas will be developed in due course in subsequent units.

The material of this chapter (as well as in Units B and C in Chapters 6 and 11) is designed to help promote transition from concrete to formal operational levels in students who are initially at the concrete operation level of intellectual development. To take advantage of this design, the instructor should direct the students to draw the pictures and use the devices described in the text. Generalizations of the observations and introduction of technical terminology should both be deferred until the students have acquired a sound grasp, at concrete level, of the phenomena being observed and described.

Questions about the observations themselves, and about inferences that might be drawn from the observations, can then produce the initial "disequilibrium" and induce the steps of "self regulation" that lead to "equilibrium" at a new level.

A test or check-out on achievement of the learning objectives of Unit A might consist of asking the student to give written or oral response to questions chosen at random from Section III of the study guide.

## 1.2 Equipment for Unit A

1. A tube mounted so that it can rotate in elevation and azimuth and be aligned parallel to a plumb bob string so as to sight on the zenith point or in the north-south direction. In a later unit the same tube can be used as a prototype device for defining and sweeping out the local celestial meridian.
2. A vertical dowel set into a portable platform or base for the observation of daytime shadows of the vertical stick. Small, portable set-ups can be used for take-home observations. Some students might be moved to make their own. If one of the laboratory windows gives access to the midday sun, a platform that can be supported out from the window sill can be very useful and encourages the making of shadow observations from the lab.
3. A simple astrolabe, for example one such as that illustrated in the Project Physics Course Handbook\*, Experiments 14 and 15, pp. 72 and 78. Such inexpensive astrolabes can easily be made out of commonly available parts or can be purchased from scientific supply houses — particularly those supplying Project Physics materials (e.g. Damon, Cat. No. 50037). Students need not be required to use the astrolabe, but some may wish to do so and should be encouraged accordingly. A simple project would involve obtaining the necessary data and plotting elevation versus azimuth of the sun for one particular day.
4. Notebooks: See Handbook Section 2.4 for suggestions concerning the nature and utilization of student notebooks.

## 1.3 Questions for unit check-outs, tests, and examinations.

(All these questions are written with the intent that students be allowed to use their notes and records in answering the questions.)

---

Report the observations you have made of either the positions of rising or of setting of the sun (by "position" we are referring to the point at which the sun crosses your local horizon). Does the position shift as the days go by? If so, in what direction?

Sketch the path you observed the sun to follow during the course of a day. Did the sun pass "directly overhead" at any time during the day?

---

Describe any observations you have made of the moon, sketching the shape of the illuminated portion, and indicating the observed angle

---

\* The Project Physics Course Handbook. Holt, Rinehart and Winston, Inc. New York. 1970

between moon and sun in each instance.

---

(a) Sketch the behavior of the shadow of a vertical stick if the shadow is marked at intervals over a period from late morning to early afternoon.

(b) Interpret the behavior of the shadow you have sketched in part (a): What information does the shadow yield about the path of the sun through the sky and its elevation above the horizon? Does the sun pass "directly overhead" when the shadow behaves as you have sketched? Explain the reasoning behind your answer.

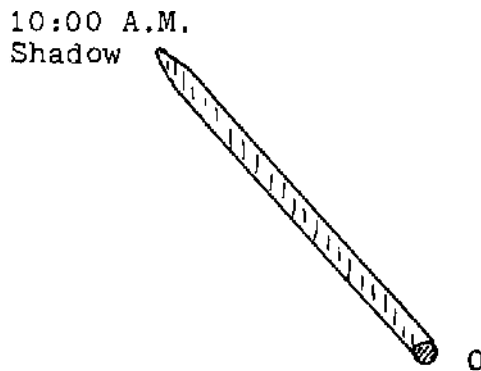

In the above figure, we are looking down on the surface of a flat, horizontal platform. A vertically oriented pin stands at point O, and, at about 10:00 A.M., the sun casts a shadow of the pin as shown in the figure.

Add to the figure some additional shadows that you might expect to observe at times other than 10:00 A.M., i.e. show what the shadow might have been at some hour earlier than 10:00 and what shadows you would expect at subsequent times, running into the afternoon. Your sketch is not expected to be quantitative, that is, you are not expected to draw a figure with numerically measured shadow lengths or angles. Just make a qualitative sketch giving an idea of how the lengths and directions will change.

Mark the particular shadow that you take to occur at local noon, and indicate why you have taken that particular one.

Mark clearly and carefully, with large, straight arrows the directions north, south, east and west on your figure and explain briefly why you have drawn your arrows as you have.

## Chapter 2

### Weighing and Balancing

#### 2.1 Content

The subject matter content of this chapter serves two purposes: (1) It paves the way for all the experimental observations leading to the law of conservation of mass, properties of materials, laws of definite and multiple proportions, and, ultimately, the atomic-molecular theory. (2) It cuts across subject matter common to virtually all of the new elementary science curricula—exploration of the conditions of balancing.

In this sequence, exploration of the general problem of balancing is motivated by questions concerning use of the rider on the equal-arm balance and justification of the linearity of its scale.

#### 2.2 Aspects of Implementation

A. We have found it very desirable, in inquiry-oriented courses of this kind, to have students work in reasonably well matched pairs. Their arguments, explanations, conversations with each other, make a very important contribution to learning and insight. Three is a crowd, however, in which at least one individual gains very little benefit. The lone wolf also loses substantially, but we have found it impossible to avoid the occasional loner; there is little point in forcing the misanthrope into associations against his will.

B. Sections 2.2 and 2.3 contain a deliberately low pressure, understated, essentially qualitative initiation of exposure to concepts of uncertainty and significant figures. These ideas will be spiralled back to in subsequent chapters and gradually made firmer and more quantitative. Our experience indicates that, at this juncture, it is not fruitful to press these issues in a more rigorous way.

C. Similarly, Sections 2.4 and 2.5 initiate a very preliminary discussion of the distinction between weight and mass. The concepts will be spiralled back to, refined, and re-defined in subsequent chapters. Attempts at greater rigour at this point are not likely to be fruitful and tend to frighten timid students.

D. It is highly desirable to constrain students to reason through balancing problems in terms of ratios, in the manner illustrated by Problem 2.8.1. Without such direction, they seek to substitute blindly into the algebraic formula (which some of them recollect from previous experience) and thus avoid both the physics of the problem and the exercise in arithmetical reasoning. Getting the right answer is the least important part of these problems, but students can easily get the right answer by substituting in the formula while avoiding any understanding of the physics. At this stage of the game, many students do not yet understand the meaning of a ratio or what is meant by



multiplying a number by a ratio or a fraction. This should be kept in mind in helping them with this material.

E. Experiment 2.7 (Balancing More than Two Objects) has a very basic importance in that it shows the ML product to be an additive quantity and provides a sound foundation for the concept of torque. This generalization of the balancing concept is not absolutely essential, however, and instructors desiring to save as much time as possible might elect to omit it. This can be done without affecting subsequent work.

F. Problems 2.8.7 and 2.8.8 are "food for thought" questions that probe, in a very preliminary way, ideas not explored in the body of the chapter: the effect of the weight of the balance beam when the beam is not pivoted at its center; the question of location of the center of gravity of the system and its influence on stability and sensitivity. These problems have not been assigned in the Study Guide, and, if the instructor desires to use them, he must direct the students accordingly.

### 2.3 Check-out

To check students on their grasp of concepts and procedures in Units 1 and 2, we have used problems and questions exactly like the ones interspersed in the body of the text and reinforced at the end of the chapter. In particular, it is very effective to ask students to make up, solve, and explain their reasoning in their own problems. In other words, the check-out should demonstrate the serious intent of the statements of learning objectives in each unit.

### 2.4 Equipment

Notebooks: Students should provide themselves with notebooks, preferably containing cross section paper so that most graphs can be plotted directly in the notebook.

Students should be advised to keep all their work in this notebook: records of astronomical observations, data and interpretation of laboratory experiments, answers to questions and problems in the text, notes on class discussions or lectures.

In the course as operated at the University of Washington, all tests are given on an open-book basis in which students may refer to the text and their own notebooks, but not other sources. All the unit check-outs and test and examination questions presented in this Handbook are designed for an open-book approach.

Experiment 2.2: Equal arm balance and weights as in Experiment 2.5, p. 14, Introductory Physical Science (IPS), 2nd edition. Prentice - Hall, Inc., Englewood Cliffs, N.J. 1972 (Prentice - Hall Science Catalogue Nos. 99265-1 and 99628-0).

Experiment 2.6: Balancing with unequal arms. Meter sticks are suspended with string tied around the center of the stick. Slotted weights (5, 10, 25, 50, 100, 200 g) with loops of thread tied to them are positioned along the meter stick. Any standard balancing equipment available from the apparatus supply houses would serve the purpose.

## 2.5 Test and examination questions

(a) In a balancing experiment like the ones you performed in the laboratory, masses are suspended on the stick as shown in the following figure:

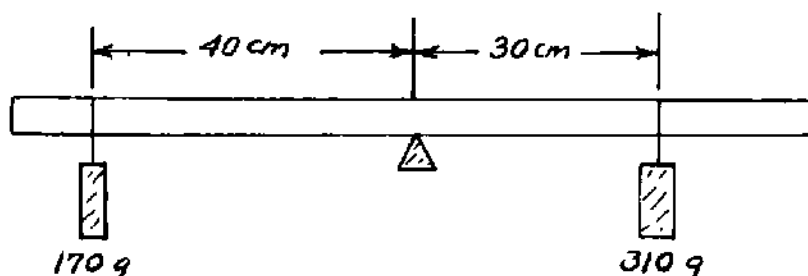

Is the system shown in the figure in balance? (Explain clearly and carefully how you arrive at your conclusion.)

(b) Using the line of reasoning illustrated in Problem 2.8.1 — not just substituting into a formula — calculate where the 310 g (in the preceding figure) should be suspended in order to balance the 170 g mass at 40 cm. Explain your reasoning.

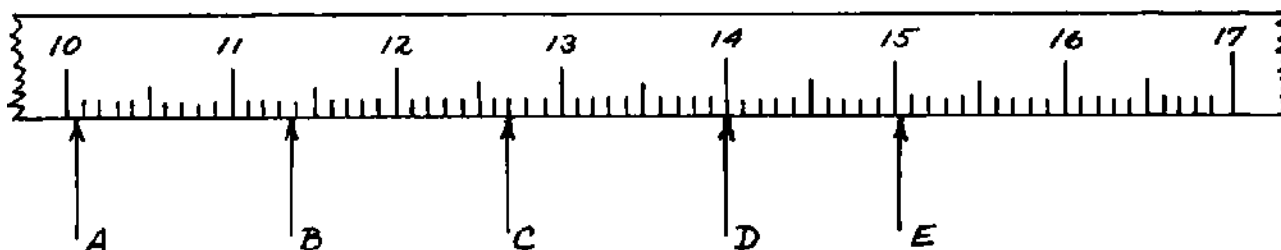

The above figure shows a portion of a scale with markings of the principal lines. Making use of the ideas and the convention described in the text (Chapter 2), write down the readings that correspond to each of the arrows in the above figure.

What problem is being implied in the following sketch? State the problem in your own words and then work out the final numerical answer, explaining each step in your line of reasoning.

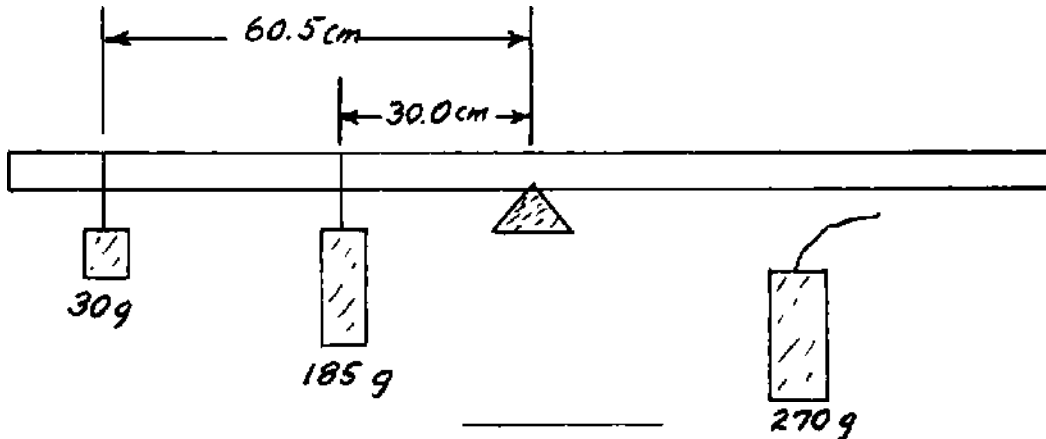

Consider a balance which is similar to the ones used in class but which differs in two respects: the fulcrum is placed so that the right arm is longer than the left arm and there are no riders on either arm. The two pans are of equal mass and are suspended at the ends of the arms.

- (a) Will the system be in balance if nothing is added to either pan? Explain your reasoning.
- (b) If you think the system will not balance in part (a), to which arm should you add some mass to bring about a balance condition? Explain your reasoning.
- (c) Assume that there is now a balance (i.e. if the arms were not balanced in part (a) you succeeded in bringing about a balance in part (b)). If two five-gram masses are now added, one to each pan, will the system be in balance? Explain your reasoning.

Suppose you have a meter stick suspended by a string at the center as shown in the diagram below. Masses of 10 and 20 g are positioned as indicated.

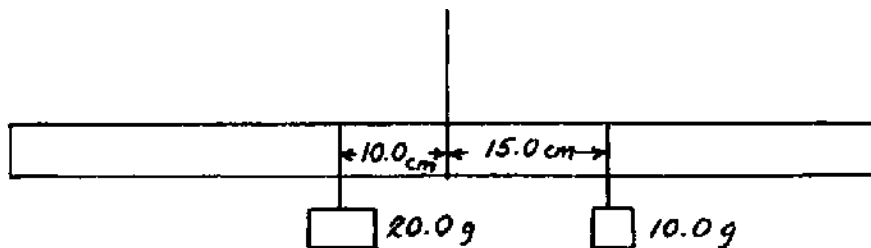

- (a) Is the meter stick balanced with this arrangement? On what do you base your judgment?

(b) If the meter stick is unbalanced, how could you balance it by moving one or the other of the weights? (At this point just give a qualitative answer, indicating the direction in which you would move the particular weight and explaining why you chose this particular direction. Do not give any numerical values.)

Now for the case you have just treated qualitatively calculate the numerical position at which you would put the weight you have proposed to move.

(c) Let us return to the initial condition shown in the diagram. If the meter stick is unbalanced, how could you balance it by either adding or removing weights at the positions shown? Do not change the positions of the weights. You may assume that you have other weights at your disposal. (Again give a qualitative answer, indicating whether you would add or remove weights from a particular side and explaining your reasoning. Do not give any numerical values.)

Now for the case you have just treated qualitatively, calculate the numerical value of the weight you have proposed to add or remove.

Suppose a meter stick is balanced with three masses attached at the positions shown in the diagram. (The two triangularly-shaped masses are made of the same material and are the same size.)

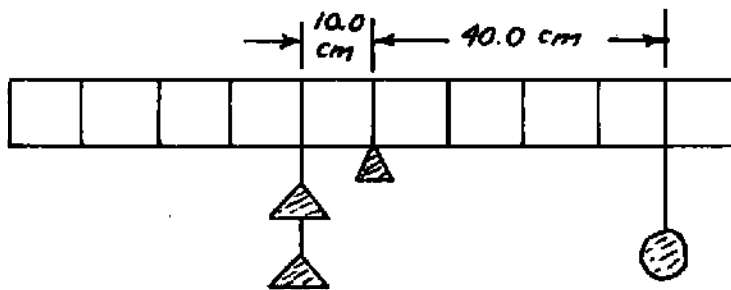

(a) The masses are rearranged as shown in the diagram below. Is the meter stick balanced with the new arrangement? On what do you base your judgment?

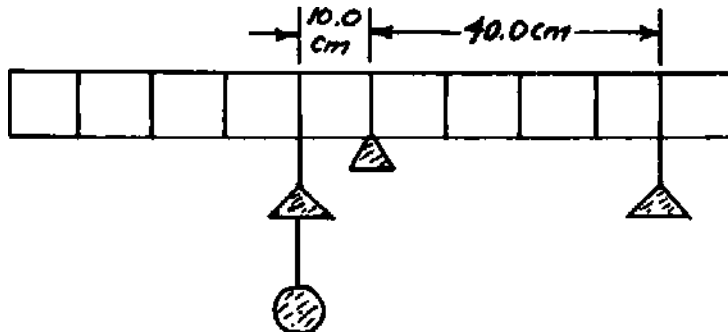

(b) If the meter stick shown in part (a) is unbalanced, discuss how you could balance it by moving the triangle on the right. Give the reasoning which enables you to decide in which direction to move the

triangle.

(c) Find the numerical position at which you would place the triangle on the right if you proposed moving it in part (b). Show all calculations.

(d) If the meter stick shown in part (a) is unbalanced, discuss how you could balance it by moving the pivot point and leaving the masses in place. Give the reasoning which enables you to decide in which direction to move the pivot point. Do not try to find the new position of the pivot point.

## Chapter 3

### Mass and Change

#### 3.1 Content

The concept of "operational definition" is explicitly introduced in this chapter in connection with the relatively familiar notions of area and volume. This is a genuinely new experience for most students (even those who are scientifically oriented and go into rather more sophisticated courses). Many students, at this point, regard a phrase such as "length times width" as a definition of "area".

This material should be given adequate time and emphasis because great stress will be laid on careful operational definitions throughout subsequent portions of the text. The idea of operational definition is also strongly emphasized in some of the elementary science curricula (e.g. Science, A Process Approach, and Science Curriculum Improvement Study, in particular) and future elementary teachers need this background in order to understand the curricular materials they will be using.

It is desirable to use questions on operational definition as an intrinsic part of any check-out at the end of this unit.

A second intellectual aspect worthy of very strong emphasis is the discrimination between observation and inference. Many students have had no experience with such discrimination and will see statements of inference as something that was "observed". The opportunity for addressing this issue arises several times through the chapter and is made explicit in each context. Problem 3.11.2 raises the issue in a simple case of volume measurement. The idea will be returned to frequently in subsequent chapters. It also plays a major role in the elementary science curricula. It is desirable to spot check the students' progress toward such discrimination in the unit check-out.

#### 3.2 Equipment

Experiments 3.2 and 3.3: The equipment, depicted in Figures 3.2.1, 3.2.2, and 3.3.1, is identical with that used in IPS (2nd edition) Experiment 1.1, pp. 3 - 5. Wood splints are obtained by splitting tongue depressors. Peg Board Kit: P.H. Science Cat. No. 99140-6; alcohol burners: Cat. No. 99126-5.

Experiment 3.7: Equipment similar to that of IPS (2nd edition) Experiments 2.7, 2.8, and 2.9, pp. 16, 17. Weighing bottles and caps, salt, ice, solutions of sodium iodide and lead nitrate.

Experiment 3.8: Equipment similar to that of IPS (2nd edition) Experiment 2.11, p. 18. Thick walled weighing bottles with caps (P.H. Science Cat. No. 99127-1), Alka-Seltzer tablets, safety glasses (P.H. Science Cat. No. 99246-1)

### 3.3 Test and Examination Questions

Out of your own notebook records for Experiments 3.2 and 3.3 on distillation of wood give at least one specific illustration of an observation made in the course of the experiments. Give at least one specific example of an inference drawn from the observations.

---

(a) Give an operational definition of the term "surface area" describing everything you do in order to arrive at the relevant numerical value—starting from the very beginning with the selection of a square to which you assign the number 1. (An accompanying sketch of an arbitrarily shaped area can save words and increase the clarity of your description.)

(b) What connection does the formula "length x width" have with your general operational definition of "area"? To what special case does it apply? Explain why it is equivalent to counting squares in this special case.

[A parallel set of questions based on "volume" is a useful alternative.]

---

Instructor:

Sketch an arbitrarily shaped area with a cross section overlay (as in Figure 3.4.1) and ask for the numerical value of the figure accompanied by a verbal description of what was done to obtain this numerical value.

---

Instructor:

Point to a surface such as a table top, chair seat, wall, ceiling, book, and ask for an estimate of the area in appropriate units together with an explanation of how the estimate was made.

Hold up a bottle, book, etc., and ask for an estimate of the volume in  $\text{cm}^3$ .

---

Suppose that a cubic box with inside dimensions 10 cm x 10 cm x 10 cm is full of water, as shown in the diagram at right.

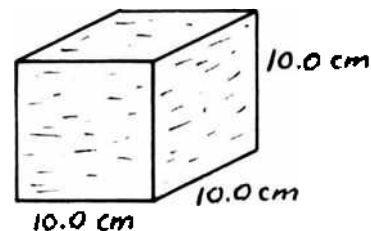

We pour this water into another box (or trough) which has a width of 5 cm and a length of 40 cm (inside dimensions), as shown in the diagram at right.

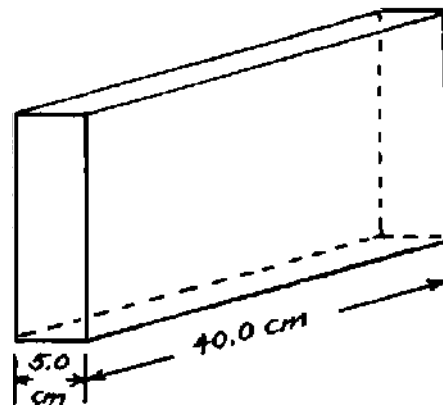

(a) Calculate how deep the water will be in the trough, explaining your reasoning carefully.

(b) Consider each of the following properties of the total amount of water:

Total mass

Total volume

Total surface area (along the walls, bottom, and free surface).

Indicate whether each one of these properties has been conserved or not conserved. Has any one of these behaviors been utilized in the calculation made in part (a)? If so, which one?

---

In geometry, the technical name for a box with rectangular sides is "rectangular parallelepiped".

Sketch two different rectangular parallelepipeds each having a volume of  $100 \text{ cm}^3$ . To keep things simple, confine yourself to cases in which the boxes have an integral (whole number) of cm along each side.

Justify your sketches by giving the operational definition of "volume" and showing that each box conforms to this definition.

---

A student measures the length of the sides of a rectangle and reports his results as follows:

Length =  $8 \pm 1$  units

Width =  $6 \pm 1$  units

(a) Calculate what, in the light of our code for presenting the results of experimental measurements, we consider to be the "best value" of the area of the rectangle.

(b) Explain the calculation you have made in part (a) by first giving an operational definition of the term "area" and showing that you have used this definition in making your calculation. (If you need refreshing on the meaning of the term "operational definition", remember that you can go back to Unit 1 for a discussion of the idea.)



(c) Calculate the uncertainty of your results (i.e. calculate the highest and lowest possible values of the area) and explain your reasoning. How would you report this information in stating the area of the rectangle? I.e., use the code we have adopted for such purposes.

(d) Present an interpretation of your calculation in part (c) in the diagram below by showing the "best" area and the extremes of uncertainty (i.e. the highest and lowest acceptable values).

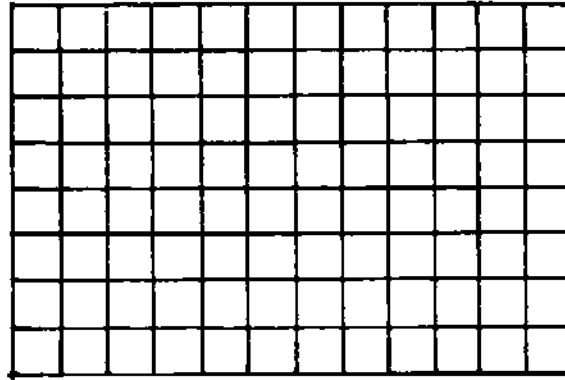

## Chapter 4

### Properties and Substances

#### 4.1 Content and Instructional Approach

The first portion of this chapter parallels material that is developed at very early stages in virtually all of the new elementary science curricula; it is therefore of particular importance to future elementary teachers. The SCIS curriculum is very explicit about operational definition of "material object", "property", "substance", etc. and devotes a great deal of time to these ideas. The unit on "Mystery Powders" in the ESS curriculum is an exercise in recognition of substance by means of their characteristic properties. Similar exercises are distributed through the SAPA materials.

Exercises such as Questions 4.1.1 and 4.1.2 are particularly valuable to the students. Most students have had virtually no practise in describing objects carefully and intelligibly in their own words. They also have had virtually no experience in observing either static characteristics of objects or changes in systems. These two questions initiate cultivation of skills which the new elementary science materials seek to develop in young children. The teachers must therefore cultivate such skills within themselves.

The slogan "idea first and name afterwards" which is enunciated in Section 4.2 is taken very literally and seriously in this text. Note that the word "density" is not injected until after the idea embodied in  $M/V$  has been examined and interpreted without giving it a name. In particular, we have not introduced the concept by saying "density is so and so."

We have found that this very careful and critical approach to language and names plays a crucial role in the development of the students' attitudes toward what they are learning. In much of their past experience, they were led to believe that knowledge resides in names rather than in an explicit and unequivocal understanding of what the names stand for and how they originate. As a consequence, students will use, casually and incorrectly, technical terms they have heard but do not understand. They do this in all innocence, not really being aware that they have no understanding of the meaning of the words.

Insisting that, before beginning to use a new technical term, students be able to describe its meaning in simple words of prior definition, plays a crucial role in the development of their understanding of scientific concepts and subject matter. This, in turn, influences their teaching and determines whether or not they will proceed to convey to children, as their teachers did to them, that knowledge resides in names rather than ideas.

It is inadvisable, at this stage of the game, to plunge into discussion of propagation of error in numerical calculations. It is far more important that students acquire a comprehension of why it is important to keep track of the range of uncertainty and what it is that we do with such knowledge. These insights are best achieved by leading the

students, in the early stages, to make the brute force calculations of highest, lowest, and best values. As they get used to doing this, one can fruitfully, in later stages, give them hints about how to short-cut the calculations. If the short-cuts are emphasized too early, concentration on memorizing the short-cut procedures distracts attention and inhibits understanding of the main logical issues; namely, the assessment of precision, decision as to significance or lack of significance in differences between measured values, etc.

The graphing of  $M$  versus  $V$  in Experiment 4.7 with the accompanying interpretation of the slope of straight lines invites setting the whole idea in a somewhat richer context, hence Experiment 4.8 on circles and the meaning of  $\pi$ . (We will use this background later on in connection with Eratosthenes's determination of the size of the earth.)

It has been our experience that very few students have any verbal or operational idea of what  $\pi$  means. If asked about circles, they will regurgitate a memorized formula (perhaps even associating  $\pi R^2$  with circumference) without having any conception of its origin or significance. As they approach the climax of Experiment 4.8, many will be heard to say "that is what they meant by  $\pi$ !" It is not that students have never been told what  $\pi$  means; they were told, but the telling was in words and formulas and not in meaningful experience. Assuming, at the college level, that all students must know what  $\pi$  means because they "had" it in school is a false and destructive assumption.

Many students will have serious difficulty with the arithmetical reasoning in the problems of Section 4.9. This material should be dealt with slowly, and additional exercises supplied as needed. Here again, as with circles and  $\pi$ , is something the students should have "had" in school. In fact, very few of them ever did the "word problems" of fourth through sixth grade arithmetic, largely because their teachers could not do the problems and therefore did not require the children to do them. The teachers were trained in colleges where it was assumed that they could do verbal arithmetical reasoning because they must have "had" it in school.

If we are to break into this vicious circle, we must do it at the college level with the future teachers and not expect it to happen through some curricular miracle in the schools. In a physical science course we have an unparalleled opportunity to meet this challenge, and it would be tragic to let it go by default. A very serious effort is made in this text to help students over this hurdle—witness Appendix A and the material of this chapter.

One must not expect all the students to master arithmetical reasoning through this chapter alone. There will be repeated encounters with similar reasoning in other contexts in subsequent chapters. Our experience has been that, after about five such encounters, approximately 80% to 85% of our students begin to perform clearly and reliably on problems like those of Section 4.9. Approximately 10% of our students appear to be unremediable and do not master this reasoning within the time that is available.

## 4.2 Aspects of Intellectual Development

We see two aspects of this chapter to be intimately associated with development of the capacity for formal reasoning; (1) emphasis on avoiding technical names prior to operational development of a concept; (2) verbal explanations of a line of arithmetical reasoning.

Unawareness of the mechanism of definition of concepts through description of shared experience strongly inhibits the transition from concrete to formal operations. The transition is visibly advanced as students become more self conscious about seeking clear definition of technical terms and recognizing when they themselves have not yet attained a sufficiently clear grasp of the meaning. If the maxim "idea first and name afterwards" is systematically adhered to, students exhibit one of the first instances of transfer of learning likely to arise in the course; they report incidents in which they sought clearer definition of technical jargon in other courses.

In the case of arithmetical reasoning, emphasis on the following sequence proves fruitful:

(a) Students should be led to translate the verbal statement of a problem into a sketch representing what is given and what is called for (or to set up a representation with readily available objects.) This provides a concrete base for the line of formal thought.

(b) Students should then be led to cultivate the habit of asking themselves, in each instance, to re-state the meaning of the key property being utilized in the problem ("density" refers to the number of grams in each  $\text{cm}^3$ ; for each group of 3.14 cm along the circumference, we have 1 cm in the diameter.)

(c) In setting up the solution to each problem, students should be required to give verbal explanations and to follow patterns such as those illustrated in Appendix A. (To find the volume occupied by 520 g of material with a density of  $3.2 \text{ g/cm}^3$ , we must find how many "groups" or "packages" of 3.2 there are in 520 because each such package corresponds to  $1 \text{ cm}^3$ ; to find the diameter of a circle having a circumference of 86 cm, we must find how many 3.14 lengths there are in 86 since each such length corresponds to 1 cm in the diameter.)

There is little value in, or progress represented by, accepting a correct answer obtained by manipulation of the formulas  $\rho = M/V$  and  $C = \pi D$ . Most students memorize the mechanism of rearrangement of such expressions and, in solving problems in this fashion, are not engaging in formal thought. They are operating at an essentially concrete level—manipulating the symbols as objects being rearranged in space according to a memorized procedure. Exactly the same applies to proportional reasoning according to a "this-is-to-this-as-that-is-to-that" routine. Students utilizing such routines are engaged in concrete rather than formal reasoning.

(d) A valuable supplement to the examples illustrated in the preceding paragraph is to ask for the volume change when 520 g of material with density  $3.2 \text{ g/cm}^3$  is removed from a block having an

initial mass of 1300 g or for the diameter change of a circle whose circumference is increased by 86 cm. Students initially see the second problem as entirely different from the first. When they begin to see the two problems as identical and recognize the equivalence between  $C/D$  and  $\Delta C/\Delta D$ , a substantial additional stride has been made toward grasp of arithmetical reasoning.

It must again be strongly emphasized that one should not expect all students to achieve control of this kind of reasoning at this point in the course. A substantial number of students does not achieve the break through until encountering additional experience in other contexts. Subsequent chapters of this text are carefully designed to provide the repeated experience that is required: solubility, composition of compounds, velocity, acceleration, etc. It is worth being patient and allowing the slower participants the repeated opportunities.

Our subjective experience strongly suggests that break through to formal level in the two categories discussed in this section (operational definition of technical terms and arithmetical reasoning with verbal explanation not rooted in manipulation of a formula) is simultaneously accompanied by advance in formal reasoning along a broad front including recognition and control of variables, syllogistic reasoning, utilization of models, and hypothetico-deductive reasoning. This is not to say that such modes of thought are all infallibly (or even skillfully) implemented; what one discerns is clearer recognition of points on which logical thought is required, a higher degree of conscious effort to engage in logical thought, and sharper sense of the correctness or error in the thinking.

#### 4.3 Demonstrations

The following two demonstrations prove to be particularly useful and effective when coupled to the concepts dealt with in this chapter.

1. Floating a lead ball in a jar of mercury (after students have hefted the ball.) Most students are very much surprised that any object of such density could possibly float.

2. The Cartesian Diver in connection with Question 4.10.7 on neutral buoyancy.

#### 4.4 Group Discussions

Problem 4.10.5 on interpreting the overall density of the earth makes for a particularly good group discussion. It generates non-trivial questions, and, at the same time, does not have any pat answers. (The high density in the interior of the earth, for example, stems both from compression and from a composition (namely, iron and nickel) other than that of rock.) In the class discussions, it is best to identify the questions and possibilities and leave them open rather than settling them by assertion of what is "known".

Generally speaking, a group discussion on some rich topic such as that of Problem 4.10.5 is a worthwhile interpolation at just about this point in the course.

#### 4.5 Significant Figures; Agreement and Disagreement in Experimental Observations

Each instructor should decide for himself on the extent to which he wishes to emphasize such matters at this juncture. For this reason, discussions of significant figures and utilization of ranges of uncertainty in experimental measurements have been relegated to Appendices C and D and are not included in the body of the text.

#### 4.6 Equipment

Experiment 4.3. Density of solids: Ruler and cubes of different metals as in IPS (2nd edition) Experiment 3.3, p.26 (P.H.Science Cat. No. 99136-4). Graduated cylinder (50 cm<sup>3</sup> or 100 cm<sup>3</sup>) for measurement of volume by water displacement. Pebbles, odd pieces of metal from machine shop scrap box, other irregularly shaped objects.

Experiment 4.4. Density of liquids: Graduated cylinder (10 cm<sup>3</sup> or 50 cm<sup>3</sup>). Small container (such as evaporating dish) in which liquid can be weighed. Sample liquids in addition to water: alcohol, burner fluid, glycerine, mineral oil.

Experiment 4.5. Density of a gas: Equipment as in IPS (2nd edition) Experiment 3.5, pp. 27 - 29.

Experiment 4.8. Circumference vs. diameter of circles: Cylindrical objects (rods, tubes, graduated cylinders, beakers, pails, etc.). Thread. Squared-off blocks of wood as in Figure 4.8.1.

#### 4.7 Test and Examination Questions

Most of the questions interspersed in the body of the text and the problems (with altered numbers) in Sections 4.6, 4.9 and 4.10 lend themselves to use as unit check-out, test, or examination questions.

---

The initial water level in a graduated cylinder rests at a reading of 45.0 cm<sup>3</sup>. A stone having a mass of 28.3 g is placed into the cylinder, and the water level rises to 54.2 cm<sup>3</sup>.

(a) From the data given above, calculate the density of the stone. Explain your reasoning carefully, as you might to a student who is

unfamiliar with the density concept but has experience with the ideas of mass and volume. In other words, you should give a clear and careful operational definition of "density" and indicate why it is worth calculating such a quantity.

(b) Using the density value you have obtained in part (a), calculate the volume that would be occupied by a stone of exactly the same material but having a mass of 180 g. Do not resort to manipulation of a formula; explain your arithmetical reasoning clearly and carefully.

When you placed an Alka-Seltzer tablet in water, a change took place. Describe very briefly what you observed; what happened to the solid Alka-Seltzer? what else was observed to happen in the system?

Consider the following two ways of carrying out this experiment: In Experiment A the small bottle containing the water is quickly capped with a rubber balloon immediately after the Alka-Seltzer is put into the water. (The balloon is initially uninflated.) In Experiment B the rigid cover is tightly screwed on to the bottle immediately after the Alka-Seltzer is put into the water.

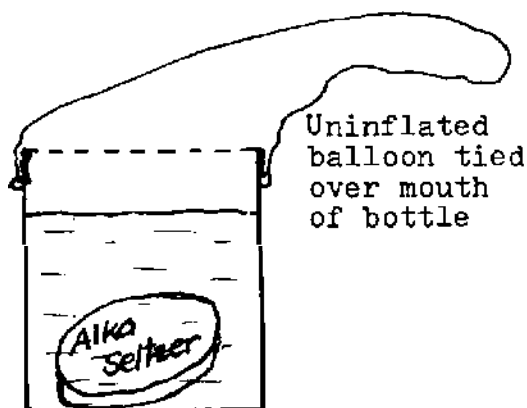

Experiment A

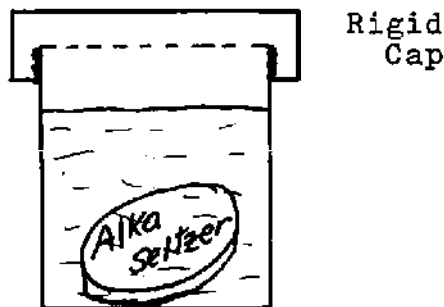

Experiment B

In each experiment (A and B) indicate what happens to the total mass  $M$ , the total volume  $V$ , and the overall density  $D$  of the system as a whole following the interaction between the Alka-Seltzer and the water. (The system consists of the bottle, the cover, and everything within.) In asking "what happens?" we are inquiring into whether the respective quantities are conserved or not conserved in each instance.

	<u>Experiment A</u>	<u>Experiment B</u>
Mass $M$		
Volume $V$		
Density $D$		

We have indicated that, on the basis of experience with many different systems and many different kinds of change, we have come to accept the Law of Conservation of Mass as a valid generalization about regularity in nature. Is it legitimate to say that there are also two other laws in nature: a Law of Conservation of Volume and a Law of Conservation of Density? Why or why not?

---

The density of iron is  $7.8 \text{ g/cm}^3$ .  
The density of lead is  $11.3 \text{ g/cm}^3$ .

- (a) Which has the greater mass:  $35 \text{ cm}^3$  of iron or  $20 \text{ cm}^3$  of lead? Explain your reasoning.
- (b) Discuss briefly the validity of the common expression, "Lead is heavier than iron."
- (c) What volume of iron has the same mass as  $20 \text{ cm}^3$  of lead? Explain carefully each step in your calculation.
- (d) Suppose we fasten together a  $20 \text{ cm}^3$  piece of lead and a  $35 \text{ cm}^3$  piece of iron. Calculate the average density of the combination. Explain your reasoning carefully.

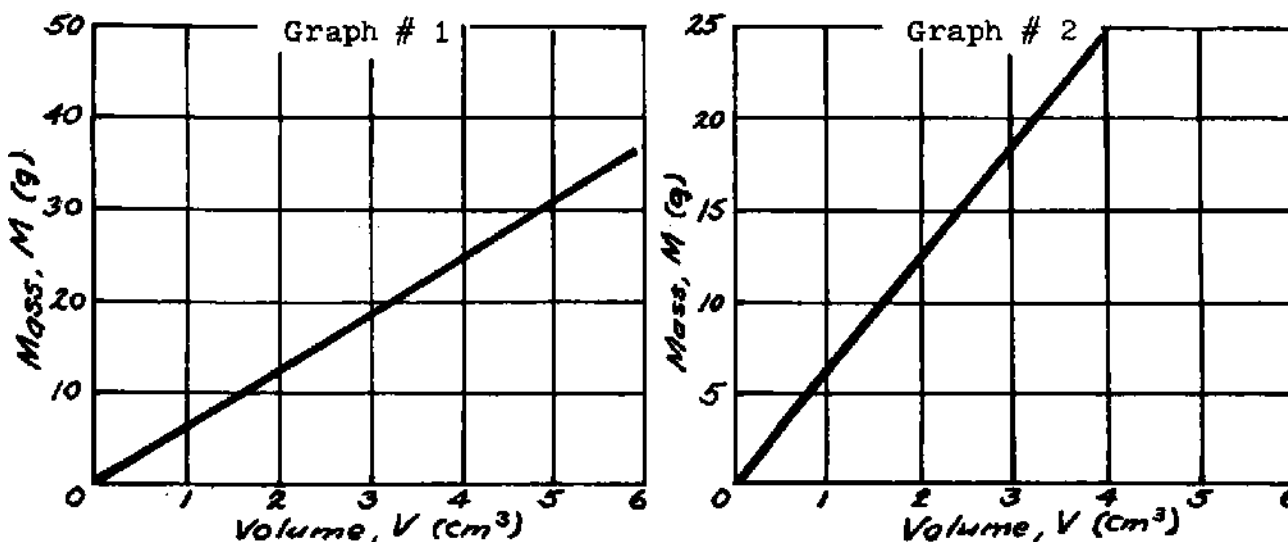

Shown above are the mass versus volume graphs obtained in two experiments performed by different students.

- (a) Calculate the density of the substance represented by each graph. Explain in words each step of your arithmetical reasoning.
- (b) Are the substances represented by each graph necessarily different substances, or might they be the same? Explain how you arrive at your conclusion.



(c) What volume would 320 grams of the substance represented by Graph #1 occupy? (Do not solve the problem by manipulating a formula. Set up the expression for the solution and explain the reasoning behind it in words, invoking an appropriate interpretation of the density concept.)

(d) Suppose we initially have a 1500 g sample of substance #1. If we remove 320 g, by how much will we decrease the volume of the sample? Explain your reasoning carefully.

---

An experiment to measure the density of air at the summit of a mountain is carried out in the following way:

The volume of a large, strong glass container is measured by determining the amount of water it contains and is found to be  $1.25 \times 10^5$  cubic centimeters. The container is then very highly evacuated (i.e. as much air as possible is sucked or pumped out of the container with a good vacuum pump), and the container is tightly stoppered. In this condition it is found to weigh  $1.550 \times 10^4$  grams.

The container is taken to the summit of the mountain where it is unstoppered and the mountain air is allowed to flow in. The container is then restoppered and weighed. It is now found to weigh  $1.561 \times 10^4$  grams.

(a) What mass of air entered the container when it was opened? Calculate the density of the air on the mountain, explaining your steps briefly. Use the power of ten notation throughout your calculation, i.e. do not just report your answer in powers of ten; express all numbers in terms of powers of ten and combine such powers in the course of the calculation. Do not keep any more significant figures than you are entitled to.

(b) One of the tables in your text gives information about densities of various substances, and in particular cites the density of air at atmospheric pressure, which is essentially the same as sea level. (See Chapter 4, Table 4.6.1)

Compare the result you have calculated in part (a) with the tabulated value. Is it larger or smaller?

What factual information emerges concerning how the density of air changes as we go to higher elevations in the atmosphere? How would you interpret this factual information? I.e., does the density variation make sense? Does it seem reasonable to you? Why or why not?

---

[In most of their experience with arithmetical reasoning, students are required to translate a verbally stated problem into an arithmetical solution. They are rarely, if ever, afforded the opportunity to reverse the line of thought and give a verbal interpretation of an arithmetical statement. In the Piagetian lexicon, the term "operations" refers to mental processes having the capacity of reversibility. We find that giving the students clear cut opportunities to reverse the arithmetical

line of thought is conducive to achieving control of arithmetical reasoning. Hence the following questions:]

A student earns \$84.00 for working 35.00 hours. Consider the number  $\frac{35.00}{84.00}$ . Interpret this number in your own words: what does it represent? what meaning does it have? (Express yourself in simple everyday words; technical terms such as "per" are off limits.)

A man walks a distance of 5.4 miles in 2.2 hours. Consider the number  $\frac{2.2}{5.4}$ . Interpret this number in your own words: what does it represent? what meaning does it have?

A tourist at a money exchange turns in \$50.00 U.S. and receives 21.20 English pounds. Consider the following number:  $\frac{21.20}{50.00}$   
Interpret this number in your own words: what does it represent? what meaning does it have?

---

In your own words and in terms of the investigation you yourself performed, explain what is meant by the symbol  $\pi$ . (In your explanation be sure to invoke the idea of the straight line and its slope or steepness.)

---

A school has a circular track. The inner lane has a radius of  $1.00 \times 10^2$  meters.

(a) What is the circumference of the inside lane? (Explain your reasoning in your own words, starting with an appropriate interpretation of the number  $\pi$ .)

(b) A runner in the inside lane races  $2.00 \times 10^2$  meters. What angle does his path subtend at the center of the circle? Explain your reasoning step by step.

---

Two runners compete on a circular track of 50 meters radius. Imagine that you are standing at the center of this track. You observe that there is an angle of about 25 degrees formed by the lines drawn from your position to the positions of the two runners. How much distance separates the two runners? Show all of your work, and explain your arithmetical reasoning.

In its very nearly circular orbit around the earth, the moon shifts through an angle of  $13^{\circ}$  in one day. The radius of the orbit is approximately 240,000 miles.

How far does the moon travel along in its circular arc in one day? Carry out the arithmetical calculation in the power of ten notation. Explain in words each step of your arithmetical reasoning.

---

Suppose that we start with a circle having a diameter of 10 cm. By how much would we have to increase the diameter of this circle in order to make the circumference 50.0 cm longer than it was initially? (Do not try to solve this problem by manipulating a formula. Set up the arithmetical solution directly, and explain your line of reasoning in your own words, invoking an appropriate interpretation of the idea behind the symbol  $\pi$ .)

---

(a) Suppose that we have a length of rope which, when laid out in the form of a circle, makes a circle 10 feet in diameter. We now cut 2.4 ft off the length of the rope. How much larger or smaller than 10 ft will be the diameter of the new circle it forms? (Using the meaning of  $\pi$ , and without using a formula, explain your solution to the problem, and calculate the result.)

(b) Using realistic numbers (drawing on Table 4.6.1, for example), make up a problem involving the concept of density— a problem in which the reasoning is essentially parallel to the reasoning in the circle problem given above. Solve the problem and explain the solution, showing that the reasoning is indeed parallel to that in (a).

## Chapter 5

### Thermal Properties and Interactions

#### 5.1 Content

This chapter has a number of objectives over and beyond the introduction of additional characteristic properties of substances:

A. The concepts of "interaction", "system", and "equilibrium" are introduced. These ideas ("interaction" and "system" in particular) are developed explicitly and operationally at a very early stage in the SCIS materials, and the concept of energy is introduced subsequently in SCIS as that which is transferred among objects that are interacting. The other elementary curricula are not as explicit in the introduction of these terms, but the ideas are present in all of them. In respect to these concepts, this chapter is intended to cut across an important conceptual element common to all the new elementary science curricula.

B. Motivation is provided for introduction of the concept of "heat", and a qualitative operational distinction is made between "heat" and "temperature". Very few students are aware of a distinction between these two concepts; they use the terms interchangeably and synonymously. Those students who have a latent awareness that a distinction exists are unable to articulate it in any clear or effective manner.

Note that, although terms such as "heating" and "cooling" are occasionally used in connection with increasing and decreasing temperature in our usual, everyday manner, use of the noun "heat" and the phrase "transfer of heat" is avoided until after the need of an additional concept has been justified—the idea first and the name afterwards.

C. Considerable effort is made in questions and problems to continue requiring practice in the verbal interpretation of graphs.

D. Considerable effort is made in questions and problems to get students to invoke, and see the connection among, a wide variety of familiar thermal phenomena. Any extent to which this awareness of everyday phenomena is enhanced in class discussion (and by further hints and questions) contributes to the students' capacity for observation and sharpens their awareness of the relevance of these new concepts to an understanding of events that take place all around them outside of the laboratory.

#### 5.2 Demonstrations

In an effort to save time, we have deliberately avoided requiring the invariably lengthy and time-consuming efforts associated with actual measurements of thermal expansion, elastic properties, etc. Any teacher who wishes to give the students this experience will find it easy to introduce the experience into the relevant sections of this chapter.

Short of having the students perform the experiments themselves, it is very helpful to introduce the following demonstrations. In most instances, the demonstration (in which the students should be able to see and manipulate the equipment even if they do not make measurements), combined with brief class discussions of the point, purpose, and meaning of the apparatus, are adequate for the development sought in this chapter.

A. Boiling of water at room temperature when the pressure is sufficiently reduced.

B. Apparatus for observing thermal expansion of solids, with emphasis on how amplification is obtained.

C. Apparatus for thermal expansion and elasticity of gases; Exhibit syringe as in Fig. 3.6.1 (Prentice Hall Cat. No. 99129-9). (Allow students to handle the syringe; many have not used a bicycle or tire pump and have not felt the pressure increase as the gas is compressed.) Place water in a syringe and allow students to obtain a direct sense of the difference in compressibility between liquids and gases.

D. Apparatus for observing stretch of wire or compression of solid bars.

We have elected not to pursue the measurement of quantity of heat, definition of the "calorie", etc. This is left open-ended in Question 5.12.9. The subject can be pursued further by introducing simple calorimetry experiments if the teacher wishes. It could also become an optional or special project sequence for some students.

### 5.3 Equipment

Experiment 5.2. Recording of a cooling curve: Same as IPS (2nd ed) Experiment 3.12, pp. 44, 45. The substances used are naphthalene and para-dichloro-benzene.

Experiment 5.5. Boiling point determination: Same as IPS (2nd ed) Experiment 3.14, pp. 48, 49. Substances that might be used: water, alcohols.

Section 5.7. Apparatus for measuring the thermal expansion of a solid is merely illustrated in this section, and the performance of an experiment is not specified. The experiment is quite time-consuming, and we have made it a demonstration and an optional excursion for students running ahead of the rest of the class. The apparatus is the same as that for IPS (2nd ed) Experiment 3.7, pp. 31-33 (P.H. Science Cat. No. 99144-8).

Section 5.9. Apparatus for measuring stretch of a wire under varying load: same as IPS (2nd ed) Experiment 3.10, pp. 40, 41. Used as a demonstration rather than as a quantitative experiment required of the students. (P.H. Science Cat. No. 99130-7).

Section 5.10. Apparatus for observing change of volume of gases with increasing pressure: Same as IPS (2nd ed) Experiment 3.11, pp. 42-

44. Used as a qualitative demonstration (including replacing gas with liquid water) rather than as a quantitative experiment required of the students. (P.H. Science Cat. No. 99129-9)

#### 5.4 Test and Examination Questions

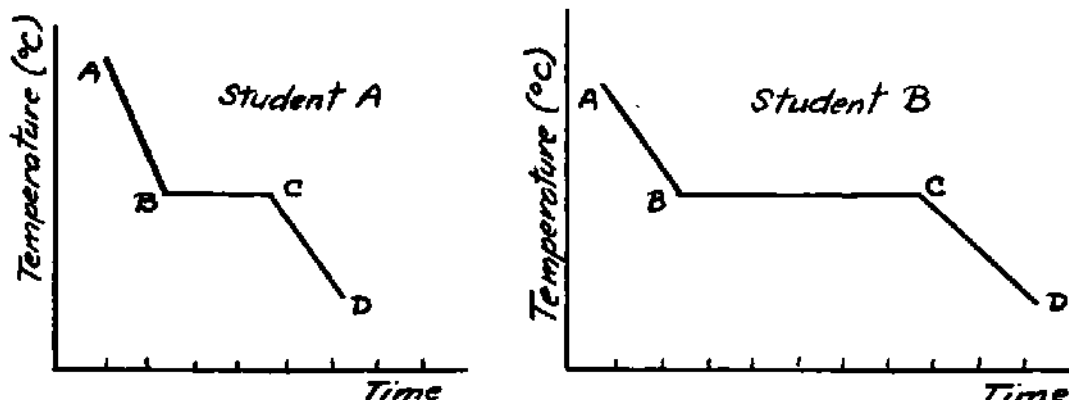

Two students each perform a cooling experiment on different samples of the same substance using the same experimental arrangement and procedures you used in class. Above, drawn to the same scale, are the graphs each obtained showing the relationship between the temperature of the substance and the time elapsed after the removal of the flame.

(a) Interpret the graph obtained by Student A by describing what is happening to the substance in the test tube during each of the intervals indicated as AB, BC, and CD respectively.

(b) How would you account for the difference in appearance between the graphs obtained by the two students? Explain the basis from which you draw your conclusion.

---

The graph below shows the idealized results of an experiment performed in a set-up similar to the one you used for examining the freezing point of moth flakes.

The substance involved is water. A "sample" of water vapour or steam is placed in a container in which the pressure can be maintained at atmospheric pressure, but none of the sample allowed to escape. The container and its contents are allowed to cool at a constant rate. The temperature of the sample is measured at equal intervals of time and plotted on the graph below. Cooling begins at point B.

The following questions pertain to what is happening to the sample during the time intervals indicated by the letters AB, BC, CD, DE, and EF on the graph. For example, during the interval AB, before cooling begins, the sample is entirely in the vapor state and the temperature is not changing.

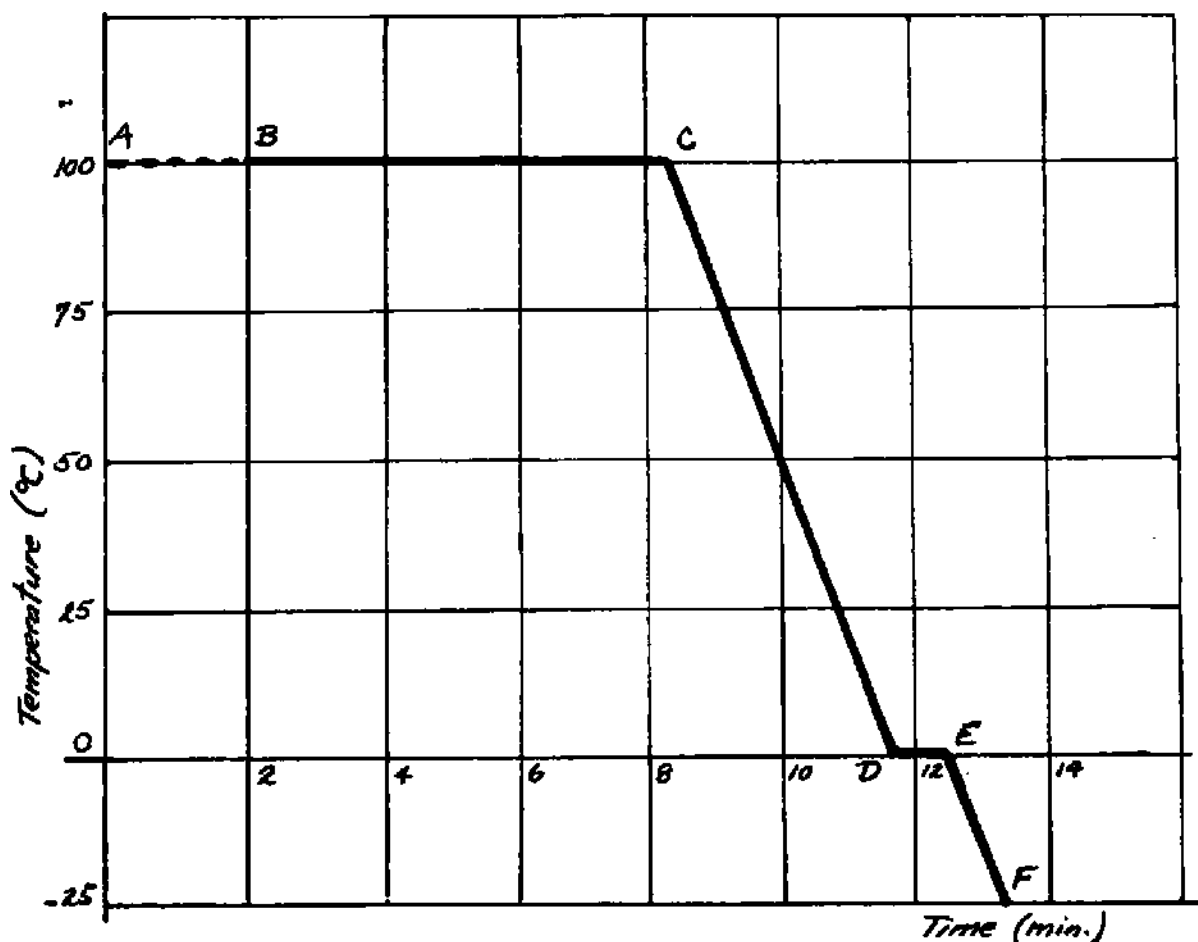

- Describe what is happening to the sample during the interval BC.
- Describe what is happening to the sample during the interval CD.
- Describe what is happening to the sample during the interval DE.
- Describe what is happening to the sample during the interval EF.

A freezing point experiment very much like the one you carried out in Chapter 5 is conducted in the manner described below and represented in the following graph.

We start with the bath at an elevated temperature and the substance in the test tube in a molten condition. The water bath is in contact with the surrounding air; its temperature decreases as time goes by; so does the temperature in the test tube, and the molten substance begins to freeze around clock reading 10 min.

At clock reading 30 min. the substance in the test tube is observed to be completely solidified. At this time a burner is placed under the water bath, and the temperature of the bath is made to follow the curve shown in the figure.

In the figure below, continue the graph for the temperature of the substance in the test tube, showing a possible history for the period between clock readings 30 and 70. (Note that there is more than one

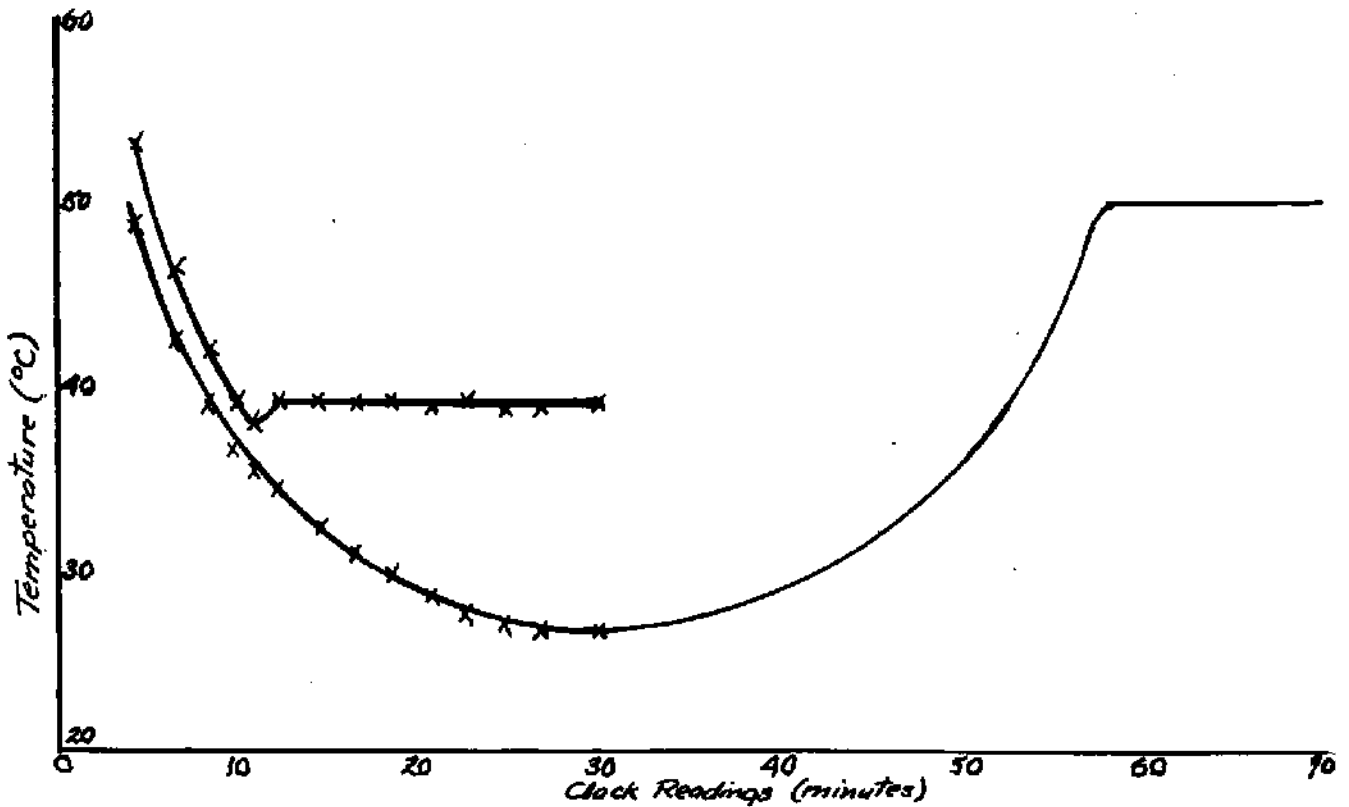

possibility and that you are being asked for a qualitative, not a quantitative, answer.) Explain the reasoning behind each portion of the curve you draw.

In an experiment on the stretching of wires, it is found that a steel piano wire, 50 cm long and 0.5 mm in diameter, increases in length (stretches) by  $3.75 \times 10^{-2}$  cm when the load hanging on it is changed by 3 kg.

(a) Interpret (or translate into words) the meaning of the number obtained from the calculation

$$\frac{3.75 \times 10^{-2}}{50}$$

(b) Interpret (or translate into words) the meaning of the number obtained from the calculation

$$\frac{50}{3.75 \times 10^{-2}}$$

Suppose that a strip of copper and a strip of iron are firmly cemented together as shown in the diagram. The two strips are initially the same length, and the initial temperature is room temperature or 20°C.

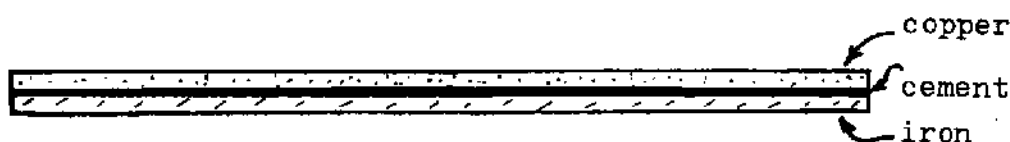



The double strip is now exposed to a flame and its temperature is increased. In the light of the information contained in Figure 5.7.2, predict what will happen to the shape of the strip; i.e., sketch what you would expect to observe happen and explain how you arrive at your conclusion. What role, if any, do properties of circles play in your line of reasoning? (Note: This is a purely qualitative problem; you are not being asked for any numerical calculations.)

---

In this question we refer to Figure 5.6.3, not so much for numerical values as for directions of change of various properties.

Suppose we start with a quantity of liquid water in a container such as one of the ones illustrated in Figure 5.6.1. The temperature is initially  $2^{\circ}\text{C}$  and we elevate the temperature to  $18^{\circ}\text{C}$ . Figure 5.6.3 gives us information as to how water behaves under such a change in temperature. In the light of this information, indicate whether each one of the properties listed below increases in numerical value, decreases, or remains unchanged relative to the initial value at  $2^{\circ}\text{C}$ :

- (a) Total mass of the quantity of water involved
- (b) Total volume of the quantity of water
- (c) Density of the water
- (d) Volume occupied by 1 gram of water
- (e) Total surface area of the quantity of water (by "total surface area" we mean not just the area open to the air, but the total area of the water body—the area of water in contact with the inside of the glass container as well as any area open to the air.)

State what is meant by a property being "conserved" or "not conserved" during a process of change, and indicate which of the above properties were conserved or not conserved, as the case may be.

---

If you hold your hand over a warm radiator in a room, you can readily feel the warm air rising toward the ceiling (you can frequently see this rising taking place if the light causes the air to "shimmer" by forming shadows against the adjacent wall.)

Note that, in a situation such as this, the temperature of the air in immediate contact with the radiator is increased, while the temperature of more distant parcels of air is not significantly affected. Making use of this hint, describe in some detail the various effects that lead to the rising of the warm air: (Present this description carefully, in terms of the scientific concepts developed in Chapters 4 and 5; ideas such as thermal expansion, density, behavior of gases, role of relative densities in the process of floating or sinking, etc.)

---

Suppose that you are a school teacher. Indicate how you would make use of laboratory experience together with appeals to familiar, everyday phenomena in order to lead your students to a clear perception of the difference and distinction between the two concepts "temperature" and "heat". (This question is intended, in part, to be a test of your capacity to adhere to our precept of "idea first and name afterwards.")

---

## Chapter 6

### "This Brave O'erhanging Firmament"

#### 6.1 Content

This chapter provides a synthesis of the observations outlined and questions raised in Unit A on astronomy. The emphasis is on discrimination between observations and inferences and on construction of models for the diurnal motion of the stars, sun, and moon and for the monthly cycle of lunar phases.

Extremely helpful at this point is a planetarium visit (if such a facility is accessible) in which the diurnal cycle is run through slowly and carefully many times while the poles, zenith point, celestial meridian, celestial equator are slowly added step by step. The difficulty with most planetarium lectures is that the lecturer tries to present the entire system in far too short a time and rushes on to "more interesting and important things." This is fatal. It takes most students at least an hour of viewing to absorb the basic facts and the relation of the speeded-up version in the planetarium to the brief glimpses he has been able to put together in his own observations.

Also extremely useful and helpful are the simple celestial spheres (Figure 6.3.1) available from most scientific supply houses. At least three of these should be available to a class of 50 students. Students should be expected to exhibit with the celestial sphere set-up all of the ideas involved in the diurnal motion (see item C in Learning Objectives.) Question 6.3.2 offers the opportunity to hammer home the perception that it is just as important to be aware of what is not the case in a given situation as to be aware of what is the case.

It is not desirable, at this juncture, to pursue subtle issues and refinements such as variation in the length of the solar day, precession of the poles, ellipticity and inclination of the lunar orbit, etc. (except with individual students who may raise specific questions that justify the more sophisticated extension of the inquiry.)

In developing the concept of a "scientific model", we are paving the way for models such as that of current electricity and of the atomic-molecular theory.

A logical issue that tends to elude many students if it is not taken up explicitly in conferences or group discussions is the impossibility of distinguishing, on the basis of the observations that are being made, between rotation of the celestial sphere in one direction or the opposite rotation of the earth. Students tend to adopt the view they have been "taught" (namely, that the earth rotates) and fail to see that all the observed phenomena are equally well accounted for by the rotation of the celestial sphere. It has never been made clear to them that there are circumstances in which one cannot discriminate between alternative scientific models and that, while this is the case, the alternative models are equally valid.

It is also worth pointing out that, even though subsequent developments in physical concepts and theories (i.e. dynamics as opposed to kinematics) lead us to accept the rotation of the earth as the model that is more consistent with the entire corpus of science, we still use the model of the stationary earth and rotating celestial sphere when it comes to terrestrial navigation.

With respect to the elementary science curricula: The subject matter of this chapter is very directly connected with the ESS units on "Daytime Astronomy" and "Where is the Moon?"

## 6.2 Equipment

Section 6.2. It is useful to exhibit a simple astrolabe or other device for sweeping out the celestial meridian and observing transits of sun or stars across the meridian (e.g. Damon\*: 50037 for the Project Physics course).

Section 6.3. A celestial sphere apparatus (such as Sargent-Welch Catalog No. 6881A Transparent Celestial Globe) is exceedingly useful in connection with all the material of both Chapters 6 and 11. It is desirable to have one such sphere per 15 or 20 students.

Section 6.4. It is desirable to have simple star charts available to the students. Suitable versions are obtainable from almost any apparatus supply house. We have made use of the Damon 50036 Star/Satellite Finder.

Section 6.9. Light from an overhead projector shining on a white sphere provides clear simulation of phases of the moon as in Figure 6.9.1.

## 6.3 Test and Examination Questions

Would you expect to see a full moon rising at midnight? Explain carefully how you arrive at your conclusion.

---

Cite several pieces of observational evidence supporting the conclusion that the moon receives its light from the sun and is not itself luminous.

---

---

\* Damon/ Educational Division, 80 Wilson Way, Westwood, MA 02090

How do you account for the dark (or unilluminated) portion of the moon when the moon is not full? Explain your reasoning.

---

Give an operational definition of "local vertical" [or local zenith, local celestial meridian, celestial pole, celestial equator, local terrestrial meridian, terrestrial equator, etc.]

---

Explain in your own words why it is not possible to decide on the basis of the observations we have been making whether the entire celestial sphere rotates from east to west around the axis through the celestial poles or whether the earth rotates from west to east about the same axis.

---

Suppose you are located at the terrestrial equator. Where in the sky would you expect to see the band of stars lying on the celestial equator? Where would you expect to see the celestial poles? Explain your answer briefly.

---

Suppose you are located at the south pole of the earth. Where in the sky would you expect to see the band of stars lying on the celestial equator? Explain your answer briefly.

---

About what time (relative to sunrise, noon, etc.) would you expect to see the narrow crescent of the waning moon rising? setting? Would you be able to see it at noontime? If so, where in the sky would you look for it? Explain your answers briefly.

---

What is your response (with reasons and explanation) to a description of a scene in which a thin crescent moon is dropping below the western horizon as the sun rises in the east?

---

Approximately in what part of the sky would you look for a full moon about three hours before sunrise? Explain your reasoning.

---

We are located in the northern hemisphere, looking southward, and we see a moon, illuminated as on the following diagram, crossing our local celestial meridian. (When we speak of "approximate times" in the following, we refer not to clock hours but to times such as sunrise, shortly before or after sunset, midnight, etc.)

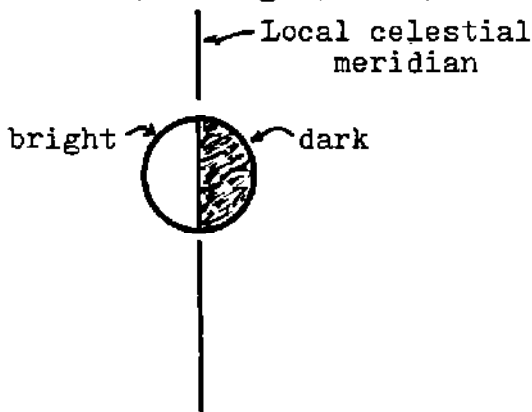

(a) At approximately what time of day or night would we see the configuration shown in the diagram? At what time would we see this moon rising? setting? Where would it be located at our local noon? (Explain briefly how you arrive at your conclusions.)

(b) Suppose we look for the moon 48 hours or 72 hours after the view represented in the diagram. About where in the diagram would we expect to see it and what will be the shape of the illuminated portion? (Answer this question by an appropriate addition to the above diagram, and then explain briefly how you arrived at your conclusion.)

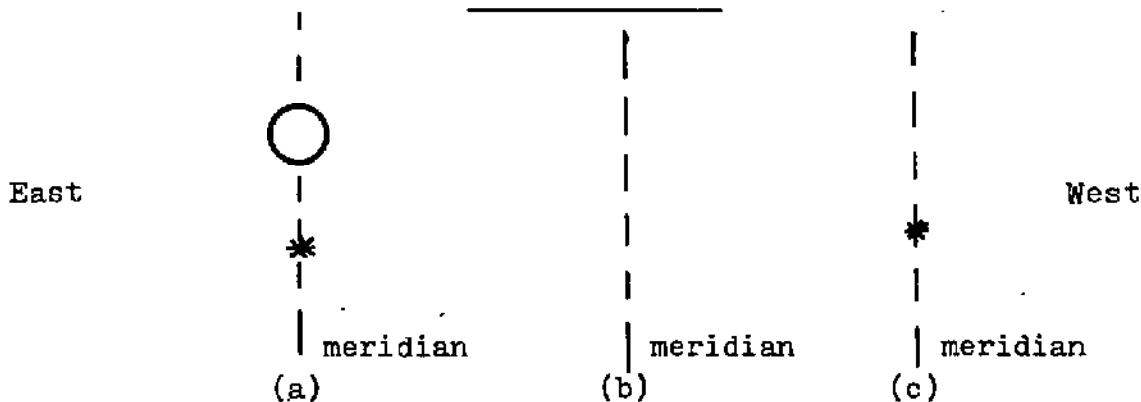

(a) Suppose looking south you observe a full moon and a reference star crossing the local meridian simultaneously as shown in diagram (a). What must be the time of day or night?

(b) Sketch on diagram (b) what the above situation (moon and star) might look like approximately three hours after the situation in (a).

(c) In diagram (c), sketch the appearance (phase) of the moon and the location of the moon when the same star crosses the local meridian 3 or 4 days later.

---

Suppose you were given the following items: a length of string, a weight that you might hang on the string, a soda straw, and a protractor. Describe carefully how you might utilize these items to determine the latitude at which you are located by making an appropriate observation of the north star. (It is fair to have a friend help you, for example by making a measurement with the protractor while you set up the other apparatus in an appropriate way.)

Carefully explain the whole operation and the line of reasoning and interpretation that goes with it. Be sure to include a geometrical diagram showing the sphere of the earth, your location on it, line of sight to the north star, etc. and explain the connection between angles and lines appearing on this diagram and corresponding angles and lines in the physical system with which you are to make your measurement.

---

Describe two different ways in which you might establish a north - south line on the pavement outside the building, one during the day, and one at night. Make your descriptions careful and complete, indicating the operations you would actually perform.

---

## Chapter 7

### Interactions Between Substances

#### 7.1 Content

The principal functions of this chapter are to

(1) extend the students' general background with respect to properties and identification of substances,

(2) contrast chemical interactions with other interactions previously explored,

(3) provide adequate breadth of context and perspective in which to set the processes of analysis and synthesis and the concepts of element and compound to be developed in Chapter 8.

Introduction of the property of solubility provides the opportunity for another set of exercises in arithmetical reasoning. At this point, following the earlier practice afforded by problems in balancing, density, and circles, many students begin to consolidate their grasp of the line of reasoning, their ability to explain it clearly in their own words, and their perception of the identity of the basic logical pattern in seemingly different physical contexts. This is a very important stage in the development of their own self confidence. Those that make the break-through at this point continue their study on a new plane of morale and enthusiasm, and they accordingly exert a strong influence on fellow students. Some students, however, still do not make the transition at this point and require the next opportunity — that which will deal with composition of compounds — to secure their grasp of arithmetical reasoning.

Distributed through the chapter are a number of instances in which students are asked to invent further questions of their own about a given situation or phenomenon ( cf. Questions 7.1.2, 7.3.1, and the paragraph at the end of Section 7.10). These are extremely important opportunities which should not be allowed to go by default. Students have rarely, if ever, asked genuine research questions of their own — however simple or primitive. They have come to believe that questions arise only in books or in teachers, and they have never had the experience of sensing how meaningful their own questions can be or how much more illuminating is an answer when it is the fruit of one's own inquiry.

Asking one's own questions is, however, a mature and sophisticated enterprise. It is unrealistic to expect students to develop this capacity instantaneously or on command. Like all other skills, this one requires practice, and the skill will be developed in different degree by different individuals. The opportunities provided in this chapter (and elsewhere throughout the text) are carefully structured. Some sample questions are given first, then hints (sometimes very obvious hints) are given concerning additional questions, and finally the door is left open for the student to continue further on his own.

Some students respond with alacrity and make rapid progress in the

sophistication of their question asking. Some students will initially fail to understand the significance of the sample questions, much less be able to articulate the additional questions that are elicited by the hints. If the opportunities are not ignored, however, virtually all students eventually begin to formulate a few questions of their own. For those who are planning to be teachers, this is a critically important developmental step.

## 7.2 Demonstration Experiment

In connection with Experiment 7.9, it is highly desirable that students have some direct experience with oxygen and its properties. (Oxygen will play a major role in the story line of Chapter 8.) Since the preparation of oxygen involves either quite high temperatures (heating of manganese dioxide or potassium permanganate to red heat) or working with substances such as chlorates or perchlorates that might be dangerous in inexperienced hands, it is suggested that oxygen be generated in a demonstration set-up provided by the staff and that students be able to bubble the gas through lime water and collect samples for the glowing splint test by coming to the demonstration generator.

## 7.3 Equipment

Experiment 7.2. Potassium chloride, potassium sulfate, sodium, chloride, test tubes, stoppers, evaporating dishes. (Similar to IPS (2nd edition) Experiment 4.1 pp. 54, 55.)

Experiment 7.5. Citric acid, sugar, naphthalene, methanol, ethanol, test tubes. (Similar to IPS (2nd ed) Experiment 4.4, p.60.)

Experiment 7.7. Metallic copper and zinc, dilute hydrochloric and nitric acids, test tubes.

Experiment 7.9. Zinc, copper, iron, magnesium, calcium carbonate, magnesium carbonate, baking soda, Alka-Seltzer tablets. Dilute hydrochloric, sulfuric and nitric acids. Lime water. Calcium carbide. Stopped test tubes of oxygen gas filled from an oxygen tank or by standard chemical preparation such as heating sodium chlorate. If time and supervision are available, students might prepare the oxygen themselves.

## 7.4 Test and Examination Questions

Consider the case in which a substance  $S$  dissolves in water. Distinguish between the terms "concentration of a particular solution of substance  $S$  in water" and the "solubility of substance  $S$  in water." (Note that in order to distinguish between the two terms you must specify clearly what each one of them means.)



---

Refer to Figure 7.3.1.

(a) Suppose that we have water at room temperature ( $20^{\circ}\text{C}$ ). How much water would be required to just manage to dissolve 500 g of potassium sulfate? Explain your arithmetical reasoning clearly and carefully.

(b) With the water still at room temperature, suppose you added 500 g of potassium sulfate to a smaller quantity of water than the amount you have calculated in part (a). What would be the final situation in the container after you had vigorously stirred the mixture and allowed dissolving to take place? Explain your answer. What would happen as you proceeded to raise the temperature of the system? Explain how you arrive at your conclusion.

---

Consider the graph for strontium acetate in Figure 7.3.1 (b). Suppose we start with a saturated solution of strontium acetate at  $0^{\circ}\text{C}$  and heat it to  $80^{\circ}\text{C}$ . What would we expect to see happening in our vessel as the heating proceeded? Explain how you arrive at your conclusion.

---

The Great Salt Lake in Utah is very salty. Let us assume it is nearly a saturated salt solution. Use only the information you need from the data given below to answer the questions asked. Be sure to explain your arithmetical reasoning in each case.

(Note that a given volume of water is almost unchanged by the addition of salt.)

At lake temperature, solubility of salt =  $35\text{g}/100\text{ cm}^3$

density of salt =  $2\text{ g}/\text{cm}^3$

density of water =  $1\text{ g}/\text{cm}^3$

volume of the lake =  $5 \times 10^{10}\text{ m}^3$ .

(a) What is the mass of salt in  $100\text{ cm}^3$  of lake water?

(b) What is the mass of  $100\text{ cm}^3$  of fresh water?

(c) What is the approximate density of the lake water? (Be sure to examine your answer to see whether it makes physical sense)

(d) Calculate the total amount of salt in the lake.

In the following question we will make use of the information conveyed in the graph below, which shows how the solubility in water of chalk (calcium carbonate) varies with temperature.

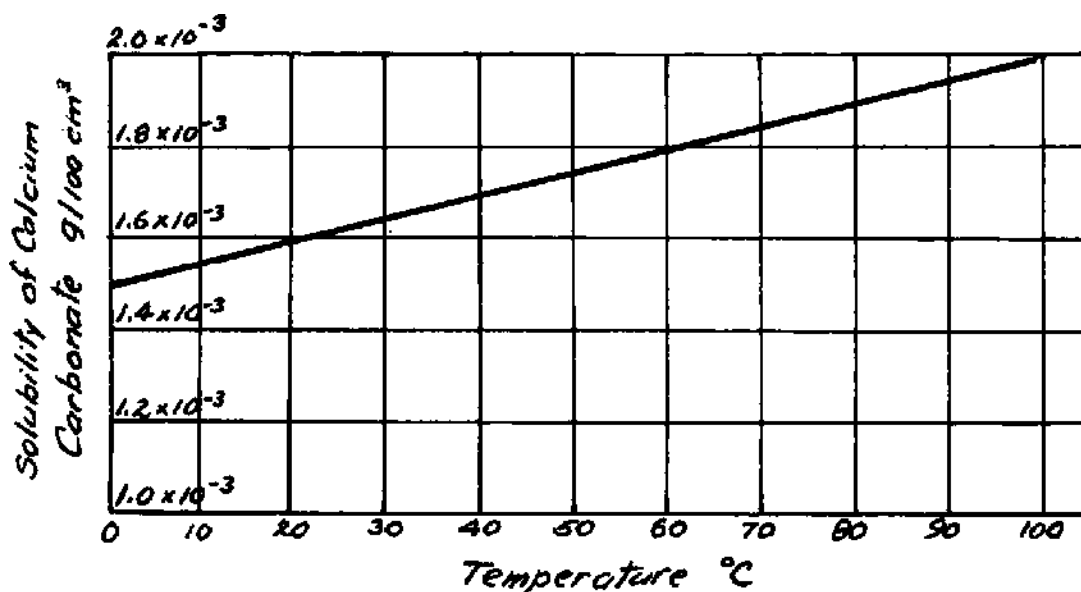

- (a) Compared with that of ordinary table salt (sodium chloride) would you say that the solubility of chalk is large or small? Back up your response with appropriate numbers.
- (b) Suppose we wish to completely dissolve 100 grams of chalk in water at 20°C. Calculate the least amount of water that we need to supply. Explain each step of your arithmetical reasoning. Carry out the calculation in the power of ten notation. Do not keep any more significant figures than you are entitled to.
- (c) Comment briefly on whether or not your numerical result in (b) makes sense; i.e. do you expect a large or small numerical value? Why? Is your result consistent with your expectations?

---

(a) Suppose we have a beaker containing 100 cm<sup>3</sup> of water at room temperature (20°C). We add 60 grams of table salt (sodium chloride) and stir until equilibrium is reached. In the light of information supplied by Figure 7.3.1(b), describe what we will now have in our beaker, giving relevant numerical values.

(b) What amounts of table salt can be dissolved completely in 200 cm<sup>3</sup> of water at 20°C? (The appropriate answer is a range of numerical values rather than a single number.) Explain your reasoning.

(c) How much water would be needed to dissolve (just barely, and form a saturated solution) 460 grams of table salt? (Make a direct calculation and explain your arithmetical reasoning in words.) What will happen if more water is used than the amount you calculate? Less water?

---

50.0 g of a solution of sodium nitrate saturated at 50°C is evaporated to dryness, and the residue of solid sodium nitrate is found to have a mass of 26.7 g. Calculate the solubility of sodium nitrate at 50°C, explaining your reasoning clearly. Is your result consistent with the information given in Figure 7.3.1 (b)?

---

Describe how you would distinguish the gases hydrogen, oxygen, and carbon dioxide from each other if you were provided with unlabelled samples.

---

In the quotation at the head of Chapter 4, Robert Boyle gives a nice illustration of an operational definition of a material substance by describing the constellation of properties characterizing the particular substance to which we give the name "gold." A somewhat more complete statement might also have contained a description of how the material is found or prepared.

In the light of this example and drawing on the record of your own laboratory experience, present an operational definition of "carbon dioxide." Make your list as complete and specific as possible. (Note that chemical formulas or name dropping about concepts such as atoms or molecules are irrelevant and inappropriate.)

---

## Chapter 8

### The Law of Definite Proportions

#### 8.1 Content

The work of this chapter establishes the Law of Definite Proportions and paves the way for construction of the atomic-molecular model in Chapter 10. Breadth of context and a matrix in which to set the otherwise very limited composition data are achieved by following the work of Lavoisier and Priestley on the discovery of oxygen and Lavoisier's clarification of the nature of combustion. The presentation leans heavily on Cases 2 and 4 in Harvard Case Histories in Experimental Science, Volume 1. James B. Conant, General Editor. Harvard University Press, Cambridge, Mass. 1957.

There are two points in the chapter at which group discussion is highly desirable:

(1) Section 8.5 and Question 8.5.1 require discussion. Without it, many students will fail to understand the nature of an hypothesis in general and will not follow the logic of the tests to which Lavoisier's hypothesis is subjected.

(2) After completion of Experiments 8.7 and 8.8, the class data should be assembled, discussed, and interpreted. Many students will still not be following the meaning of the arithmetical ratios and composition percentages. The Law of Definite Proportions should then be articulated and the ability of the students to do Problems 8.9.1 and 8.9.2 verified. The numbers should be calculated and talked about—by members of the class, not by a lecturer.

The comment at the end of Section 8.11 is worth serious attention. Many students expect to receive immediate, pat, verbal answers to any question that is raised. Those who go on to be teachers communicate this expectation to children, and such an expectation is profoundly destructive of exactly the attitudes of inquiry and reservation of judgment that the new elementary science materials seek to cultivate. The students should be helped to see that the immediate injection of jargon about atoms, molecules, electrons, nuclei, electrical charge is meaningless at this stage and violates the "how do we know . . . ? why do we believe . . . ?" attitude defined in Chapter 1.

It is very helpful for the students to begin to realize that the first men to ask these questions lived and died without themselves ever penetrating to the answers.

Study Guide Unit 8, dealing with the flame tests and spectra, has deliberately not been incorporated in the body of the text. It can be omitted without breaking the logic line of the text development, and pressure of time may well demand this omission. These observations, however, are greatly enjoyed by the students; they consider them a "fun" experiment. The unit lends itself readily to optional activity or to use as a special project for those students who are progressing more rapidly than the rest of the class.

## 8.2 Equipment

Experiment 8.1. Powdered metallic copper, alcohol burner, small crucible, triangle to support crucible in peg board. (Similar to IPS (2nd ed) Experiment 6.6, p.108.)

Experiment 8.2. Powdered charcoal, burner, test tube, stopper, glass and rubber tubing. (Similar to IPS (2nd ed) Experiment 6.7, p.110)

Experiment 8.7. Metallic zinc (shiny metal, not "mossy zinc"), test tube, beaker, evaporating dish, burner, burner stand. (Similar to IPS (2nd ed) Experiment 6.4, pp. 103-105.)

Experiment 8.8. Electrolysis of water. (Similar to IPS (2nd ed) Experiment 6.2, p.100.) Easily improvised from usually available materials: 6v battery, test tubes, beaker, electrodes, sodium carbonate as electrolyte. (P.H. Science Cat. No. 99240-4)

## 8.3 Tests and Examination Questions

State in your own words what is meant by the term "Law of Definite Proportions." Give specific illustrations of systems which do obey this law and of systems which do not obey it. What relevance does this law have in helping us establish the concept "true chemical compound?"

---

Explain in your own words the following aspects of Lavoisier's experiment illustrated in Figure 8.5.2: How do you interpret the fact that the mercury level rises in the bell jar as the red calx forms in the retort? How do you interpret the fact that the level eventually stops rising? How do you interpret the fact that the mercury returns to its original level when the calx is decomposed? How are these observations and interpretations related to the observed fact that the gas collected directly from heating of the red calx in other experiments (in the absence of air) is not identical with air in its properties?

---

Give an operational definition of the term "oxygen."

---

When a mixture of the elements copper and sulfur is heated, a compound is formed (called copper sulfide) which, in accordance with the Law of Definite Proportions, is always found to contain 66.5% copper.

(a) What is the connection, if any, between 0.665 g of copper and 1.00 g of the compound?

(b) Interpret, in words, the meaning of the number  $\frac{66.5}{33.5}$ .

(c) Suppose that 5.20 g of copper are heated with 3.60 g of sulfur. Will either one of the two substances be left over, unreacted? If so, which of the two is left over? How many grams? Explain your reasoning as you make your calculations.

(d) If 5.20 g of copper are heated with 3.60 g of sulfur, how many grams of copper sulfide will be produced? Explain your calculation.

---

Recall Experiment 3.2 on distillation of wood: In the light of the experience you have accumulated and concepts you have formed, would you characterize the changes taking place in the distillation as chemical or physical? Is wood to be regarded as a mixture or solution of the substances obtained in the distillation or as a compound (or perhaps a mixture of compounds)? Support your answers by citing specific observations from your own notes.

---

Water is known to be a chemical compound of the two elements hydrogen and oxygen. Any sample of water is always found to contain 11.2% hydrogen, in accordance with the Law of Definite Proportions.

(a) Calculate, to the appropriate number of significant figures, how many grams of hydrogen combine with one gram of oxygen to form water. Explain your reasoning in your own words.

(b) Suppose that 5.00 g of hydrogen and 5.00 g of oxygen are mixed and exploded. How many grams of water can be produced in this experiment? Explain the reasoning behind your calculation.

---

(a) In your own words describe what is meant by the term "Law of Definite Proportions" and use the tabulated class results on the zinc chloride experiment to illustrate this law.

(b) Does a solution of salt in water conform to the Law of Definite Proportions? Explain your answer.

---

Saturated solutions of a solid in a liquid have a very definite concentration at a given temperature and therefore have a very definite percentage composition under these circumstances. Would you say that a saturated solution obeys the Law of Definite Proportions and must therefore be an example of a chemical compound? Why or why not?

## Chapter 9

### Batteries and Bulbs

#### 9.1 Content

The unit on current electricity is a deliberate digression from the sequence on the structure of matter. We have found it to provide a welcome change of pace and focus at this particular juncture, allowing the preceding material time to be digested and allowing an additional exercise in model building before encounter with the more elusive logical subtleties inherent in the atomic-molecular theory. Since this chapter stands by itself, however, there is no obstacle to its being deferred, transposed or eliminated at the discretion of the instructor. Such alterations will not impair the coherence of other sequences and will not generate gaps that require ad-hoc filling.

The content of this unit is particularly closely related to the ESS unit on Batteries and Bulbs, but it also cuts across several sections of SCIS and SAPA. The background of pre-service and in service elementary teachers is very weak in this area, and strengthening of this background can be particularly fruitful both because of children's interest in electricity and because of its occurrence in the content of the elementary curricula.

It should be explicitly noted that this sequence starts with phenomena of current electricity and builds the electric current model without prior encounter with electrostatic phenomena and the concept of electrical charge. As a matter of fact, the concept of electrical charge, since it derives from experience with electrostatic interaction, has no place in this sequence, and the term is carefully avoided because time is not being taken to give it an honest operational meaning or to establish the phenomenological connections among electrostatic phenomena, voltaic cells, and current-carrying circuits.

Instructors who have not thought about such a sequence before and who are used to starting with the concept of electrical charge will find it desirable to review the present logical structure carefully. It is perfectly possible to build a viable, albeit limited, model for what happens in voltaic circuits by drawing only on direct observations of such circuits, but the sequence is not one that many of us have tried to examine and justify. The students take to it very amenably, however, and it helps remove their fear of the verbal abstractions they felt they were supposed to have understood and never did.

This material offers a singularly good opportunity for a term paper assignment. The assignment might consist, for example, of the student's describing in detail his own sequence of experience in attaining the learning objectives specified in items II A and B of the Study Guide (Section 9.13).

## 9.2 Demonstrations and Additional Exercises

A. It is desirable to have several bulbs, with intact filaments but broken-away glass envelopes, available for examination of the structure of the bulb.

B. It is desirable to cut one or two dry cells with a band saw in such a way as to reveal the internal structure in cross-section and have these cut-aways on display.

C. The quickly drainable and rechargeable "wet cells" mentioned in connection with the experiment involving lifetime of cells (Experiment 9.9 B) are lead-sodium sulfate cells, the construction and handling of which are described in Chapter 1 of "Probing the Natural World," Volume 1, Intermediate Science Curriculum Study Group, Silver Burdette Co., Morristown, N.J. 1970.

D. Although such activity has not been specifically included in the work and problems of this chapter, the material readily lends itself to the introduction of "logic boards", in which the pattern and connection of hidden electrical wiring is to be inferred from access to the terminals available at the surface. Both ESS and SCIS make use of such logic boards and engage children in the attendant detective work. An instructor may well wish to expose future teachers to such exercises.

## 9.3 Equipment and Materials

1.5v cells (2 or 3 per pair of students). Size D flashlight cells are adequate for exploratory purposes and for some of the experiments. Large telephone dry cells, however, last considerably longer, are somewhat more convenient to use, and work better in those experiments in which lower internal resistance is desirable.

Flashlight bulbs (5 or 6 per pair of students), screw base, rated for use in 2-cell flashlights. It is desirable to obtain homogeneous lots of bulbs in large quantity: (a) Loss, breakage, and burn-out rates are high; (b) Brightness of the bulb is used as an index of current in many of the experiments, and it is therefore desirable to have very nearly identical bulbs. Different makes and lots of bulbs of essentially the same rating frequently turn out to be very inhomogeneous in their brightness under similar circuit conditions.

Lengths of hook-up wire (10 per pair of students).

Screw base sockets (5 or 6 per pair of students).

Knife switches, or improvisations out of brass fasteners and hook-up wire (one per pair of students).

Fahenstock clips or other connectors.

Nichrome wire



(Complete kits of suitable materials are available in connection with the Elementary Science Study Unit "Batteries and Bulbs", Webster/McGraw-Hill, St. Louis, MO.)

Experiment 9.9 B. The "wet cells " referred to in this experiment are lead sulfate cells utilized in the Intermediate Science Curriculum Study (ISCS) junior high school course and described in "The Natural World" Volume 1. pp. 4-8. Silver Burdette Co., Morristown, N.J. 1975.

These cells can be charged with a conventional storage battery (see Figure 9.9.1). When charged for periods of minutes, they run down (to undetectable glow of flashlight bulb filament) in the same order of time. To obtain reasonable reproducibility of observations, a cell should be charged, run down to just vanishing of the glow of a bulb, and then charged for a measured time and run down to the same endpoint in successive experiments with parallel and series combinations of bulbs.

Experiment 9.9 C. The steel wool should be fine strand (grade 0 or 1); coarse strands will not burn out as more current is drawn. It is desirable to use a fresh telephone dry cell; size D flashlight cells have too high an internal resistance to work well in this experiment. If the steel wool strand still does not burn out in these circumstances, suggest the use of two cells in series — a combination students will explore in Experiment 9.11.

#### 9.4 Test and Examination Questions

Out of your own record of observations and experiments with batteries and bulbs, list those bits of evidence that motivate the invention of the idea of an invisible current or flow of something through the circuit connected to an electric battery.

---

Is there any non-conducting material in the construction of a standard socket besides the ceramic base, i.e. inside the socket itself? If so, what is it there for? What would happen if it were not there?

Show with diagrams the experiments you carried out that are relevant to these questions.

---

Suppose you start with two identical bulbs connected to the battery in series as shown in the diagram (a) below.

Predict what will happen to the brightness of the first bulb if a third bulb is hooked in parallel to the second bulb, as shown in diagram (b) below.

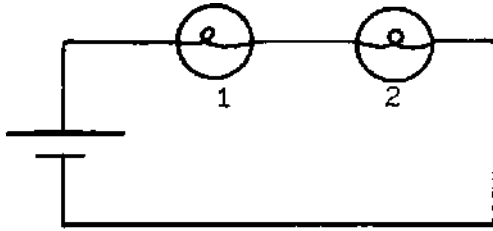

(a)

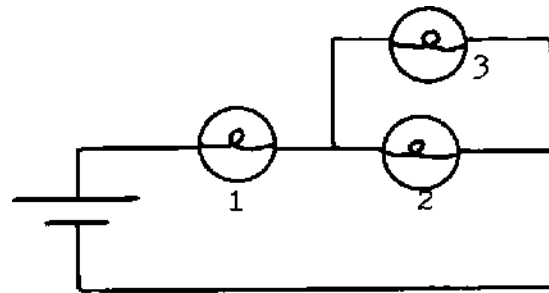

(b)

Give a brief explanation of how you arrived at your prediction. (Think carefully about the experiments you have done in class that are relevant or from which you can draw inferences to this situation.)

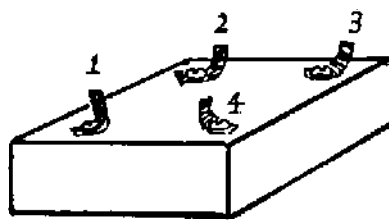

A wooden box has four metal terminals which may or may not be connected to each other with wires inside the box. A student makes some tests to find out about the internal connections.

(a) The student connects a battery and bulb between terminals #1 and #2, as shown below, and finds that the bulb glows brightly.

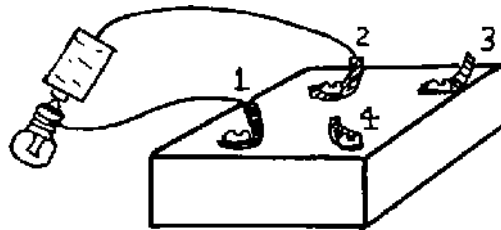

What do you conclude about the nature of the connection between terminals #1 and #2 inside the box? (Give your reasons.)

(b) The student then moves the wire at terminal #2 over to terminal #3 and finds that the bulb does not light. What do you conclude about the nature of the connection between terminals #1 and #3 inside the box?

(c) The student then connects his test bulb and battery to terminals #3 and #4 and finds that the bulb glows brightly. What do you conclude about the nature of the connection between terminals #3 and #4 inside the box?

(d) Draw a wiring diagram of the inside of the box, showing the four terminals and the connections among them.

(e) Is there a conducting path between terminals #2 and #4 inside the box? Explain how you arrive at your conclusion.

In the following pairs of diagrams (a), (b), and (c), do the two drawings (1) and (2) represent equivalent circuits or different circuits in each case? (By equivalent circuits we mean that all effects such as brightness of the bulbs and the drain on the battery in the two drawings are the same regardless of how the wires are hooked up.) Explain briefly how you arrived at your conclusion in each case.

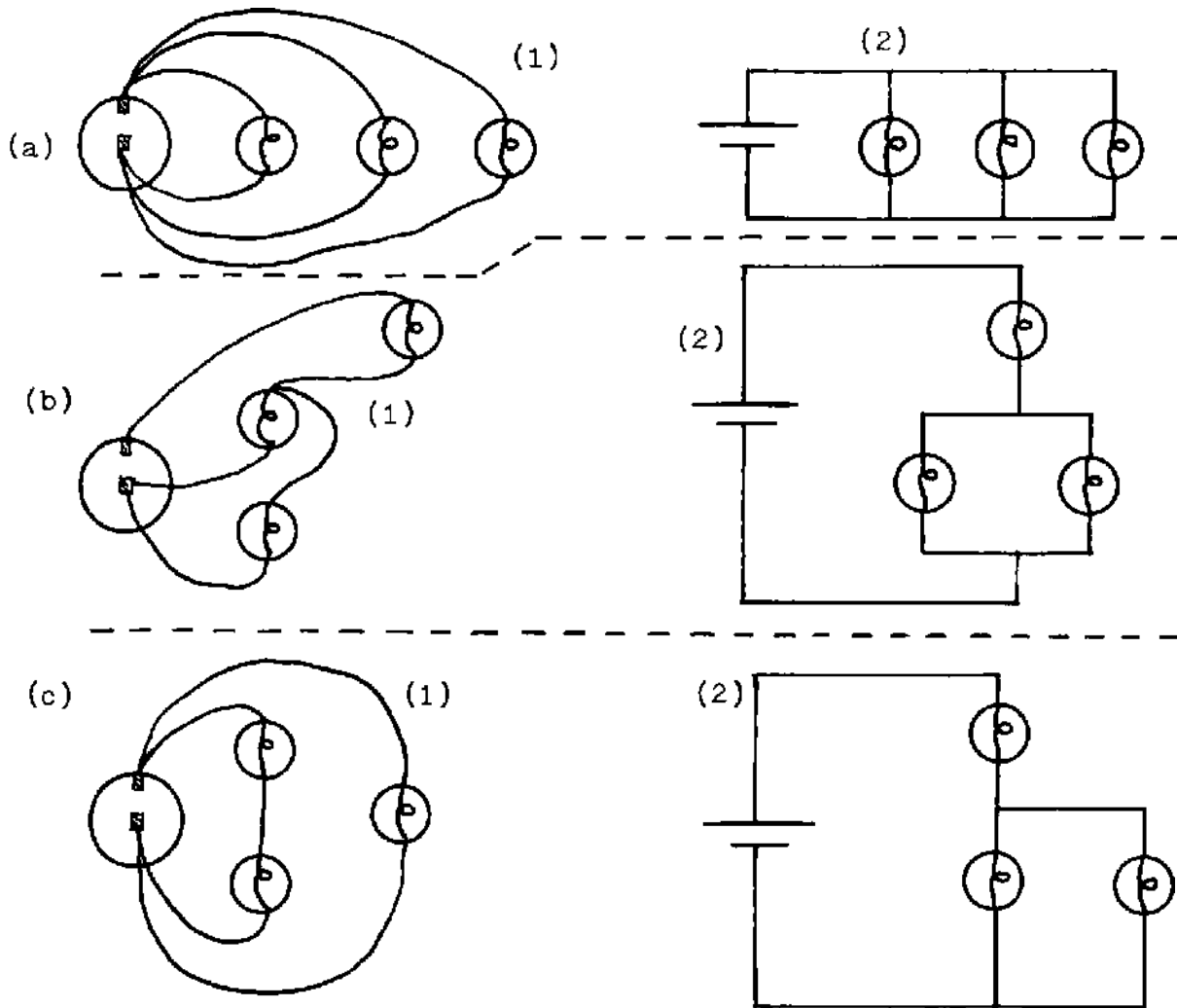

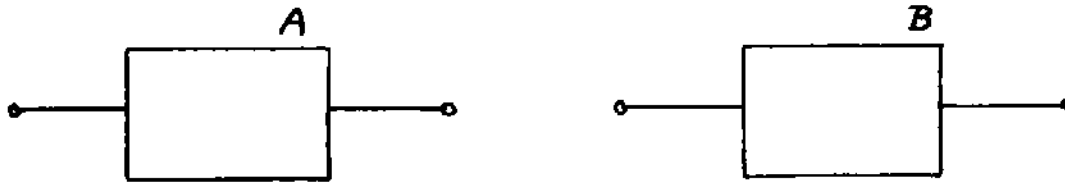

(a) Two sealed boxes are placed before you, as shown above. Two wires extend from each box. Using only the materials available to you in the batteries and bulbs unit, how would you determine which of the two boxes would present the lesser resistance to an electric flow? Explain your reasoning, showing diagrams of the arrangements you would use to make the necessary tests.

(b) The two boxes are opened and found to contain the arrangements of bulbs and wires shown in the two diagrams below. Drawing on your experiences in the classroom and the discussion of resistance you have given above, argue which of the two configurations has the lesser resistance.

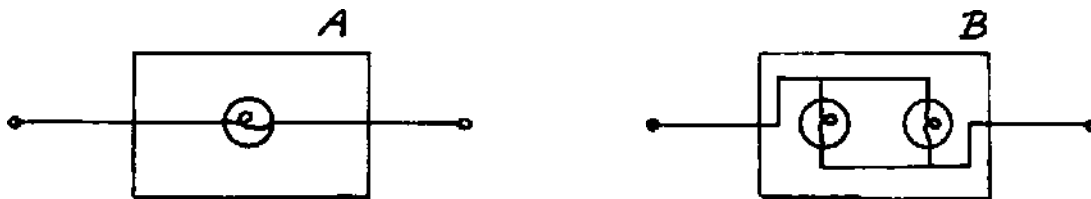

Three identical light bulbs are connected as shown in the circuit diagrams below.

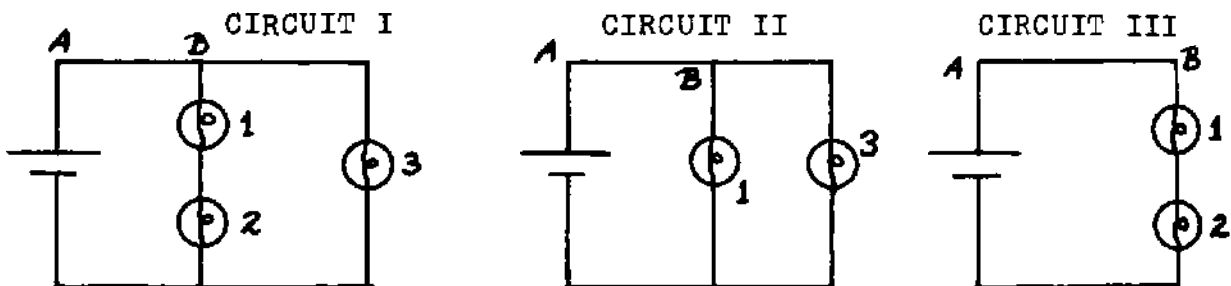

(a) How does the brightness of bulb 1 compare in each of the three circuits? i.e., mentioning circuits by number, indicate where bulb 1 glows with the greatest, least, or intermediate brightness. If the brightness is the same in two or more circuits, say so. Indicate what information you make use of to arrive at your conclusion.

(b) How does the brightness of bulb 2 compare in Circuit I and Circuit III? Explain how you arrived at your conclusion.

(c) How does the brightness of bulb 3 compare in Circuit I and Circuit II? Explain how you arrived at your conclusion.

(d) Compare the strength of flow in the wire between points A and B in each of the three circuits shown (i.e. in which circuit is there the most flow through the battery? the least flow? etc.) Explain your reasoning.

(e) In circuit I what happens to the brightness of bulbs 2 and 3 when bulb 1 is removed from its socket? Indicate how you arrived at your conclusion.

---

We start with four identical bulbs connected to a battery as shown in the following diagram. The battery is strong enough to light all the bulbs.

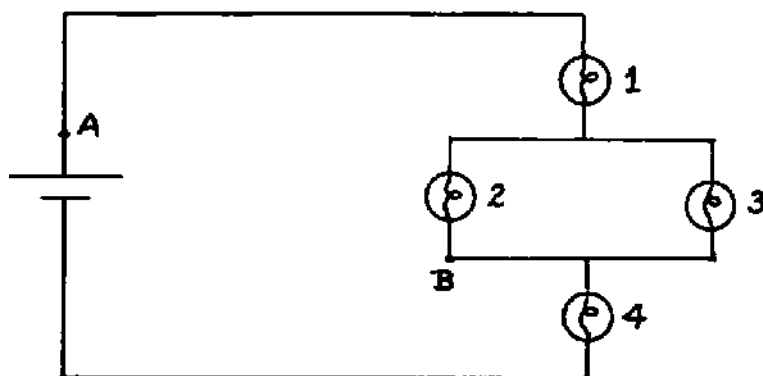

(a) When all the bulbs are screwed into their sockets and lighted, how do the brightnesses of the four bulbs compare with each other? Explain your reasoning.

(b) Predict what will happen to the brightness of bulbs 1, 2, and 4 in the above situation when bulb 3 is unscrewed so that it no longer lights. Explain your reasoning. (Be sure to compare the final brightnesses not only with each other but also with the condition preceding the unscrewing of bulb 3.)

(c) Suppose we go back to the initial condition with all four bulbs screwed in and lighted. We now connect a wire between the points labelled A and B on the diagram. Predict what will happen to the brightnesses of the four bulbs. Explain your reasoning.

---

Metals are not the only conductors which can be used in a circuit. In the electrolysis of water experiment, the sodium carbonate solution is also a conductor.

Suppose we set up the circuits shown in the diagram below. In each beaker the stainless steel electrodes are the same distance apart, and the sodium carbonate solutions are identical. The oxygen is allowed to escape into the air. The hydrogen is collected in test tubes as shown.

The switches in the three circuits are closed simultaneously. The hydrogen gas is collected for some fixed time, then the switches are simultaneously opened.

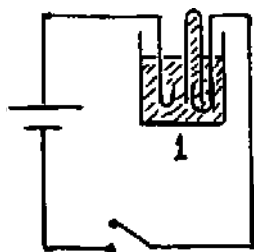

CIRCUIT I

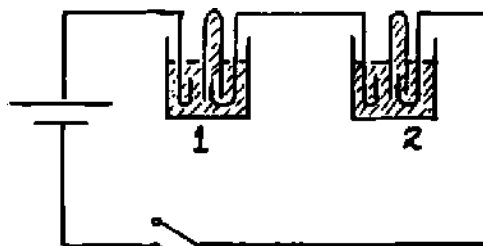

CIRCUIT II

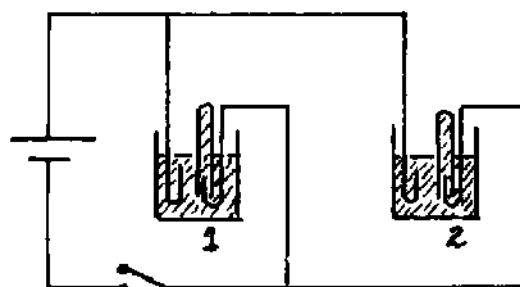

CIRCUIT III

Let us assume that the electrolysis cells behave very much like a light bulb as far as offering resistance to electric current is concerned. On the basis of this assumption and your own experience in the electrolysis experiment, let us make some predictions about what we might expect to observe in the three experiments sketched above.

(a) How might you expect the volume of hydrogen gas collected in test tube 1 to compare in each of the three circuits? i.e., mentioning circuits by number, indicate where the largest, smallest, and intermediate volume of hydrogen is collected in test tube 1. If the volume is the same in two or more circuits, say so. Explain how you arrived at your conclusion, using the flow model and concepts developed in the Batteries and Bulbs unit.

(b) How would you expect the volume of hydrogen gas collected in test tube 2 to compare in Circuit II and Circuit III? Explain your reasoning.

(c) It is perfectly possible to make a battery of "wet" cells that would run the electrolysis process for a while and run down in a measurable time, as in the laboratory experiments you had the opportunity to perform. Suppose we were to construct three identical wet batteries to run each one of the circuits shown in the diagram above. How does the time for the battery to run down compare in each of the three circuits, i.e. indicate in which circuit the battery lasts the longest, shortest, or intermediate length of time. If they all run down at the same rate, say so. Explain how you arrived at your conclusion.

## Chapter 10

### The Atomic-Molecular Model

#### 10.1 Content

This chapter develops a basis for accepting Dalton's atomic-molecular model—without going all the way through the subtleties associated with the final rationalization by Cannizzaro of molecular formulas and the table of atomic masses. The latter part of the story could constitute a collateral reading project for students who become interested, and the supplementary references are listed at the end of the chapter.

The necessity of molecular motion will be invoked subsequently, and the kinetic-molecular model will be developed in connection with the chapters on dynamics. This chapter is the first step in the development of the corpuscular model. There will now be a digression to kinematics in Chapter 12, and the sequence will be continued later.

Many students have very great difficulty perceiving the logical significance of the fastener and ring experiments. They fail to translate them as models of the invisible model. They also have particularly serious difficulty with the arithmetic of the Law of Multiple Proportions as well as with the logical implications of the Law. We have found no magical solution to these difficulties. One must handle this material slowly, dwell on it with several repetitions, and stimulate as much discussion as possible—getting students to explain it to each other—but it is necessary to monitor their discussions for correctness. Many are likely to say absolutely incorrect things and mislead fellow students. Many students perceive the logical sequence more readily if they are pressed to give an explicit answer to the question at the very end of Section 10.6: what conclusion would the fasteners-and-rings observations force them to if it were found that compound substances did not obey the Laws of Definite and Multiple Proportions?

In general, it is very important (as everywhere else throughout this text) to make sure that the students are responding to the questions that require verbal explanation of their lines of reasoning. If this requirement is not stressed, students will ignore the questions. In doing so, they will fail to develop the logical insights we are striving for; they will fail to improve their capacity for arithmetical reasoning, and those who are future teachers will fail to arrive at the point at which they might deal competently with the inquiry-oriented elementary science curricula.

Question 10.7.3 is a particularly fruitful basis for a class discussion. Devil's advocates who espouse a continuum point of view should be encouraged and supported. Attempting to create a rational continuum model, regardless of the fact that it will not be successful, is an interesting intellectual challenge.

When the devil's advocates are pressed to the wall and begin to take refuge in statements to the effect that materials behave as they do in such-and-such circumstances "because they want to", there is an opportunity to point out that such teleological or occult properties on the part of inanimate matter are exactly what the 17th century natural philosophers sought to eliminate from science.

Any tendency on the part of the students to introduce molecular motion as a component of the corpuscular model is worth encouraging at this point, but this aspect should not be introduced gratuitously or because they have "heard" about it previously. It should be invoked only as a way of accounting for some of the phenomena under consideration—for example, the fact that the molecules of a gas continue to fill the entire volume available to them and do not fall out on the bottom of the container.

## 10.2 Equipment

Experiments 10.1 and 10.6: In the text these "experiments" are described in terms of the brass fasteners and rubber rings utilized in IPS, 2nd edition, Experiments 8.4 and 8.5, pp. 142-145 (Prentice-Hall Science Catalog No. 99134-9). Perfectly adequate substitutes might be improvised from nuts and bolts, paper clips of different sizes hung together, etc.

## 10.3 Test and Examination Questions

Suppose we have two compounds formed of elements A and B with the following percentage compositions:

	<u>% A</u>	<u>% B</u>
Compound I:	25%	75%
Compound II:	50%	50%

A student, when asked to examine the above data to see whether or not they illustrate (1) the Law of Definite or Constant Proportions, and (2) the Law of Multiple Proportions, made the following statements:

"(1) The Law of Definite Proportions is illustrated by the fact that no matter how many grams of compound I we analyze, it is always 25% A and 75% B by weight.

(2) The Law of Multiple Proportions is illustrated by calculating the following ratios:

$$\frac{\% \text{ A in Compound II}}{\% \text{ A in Compound I}} = \frac{50\%}{25\%} = \frac{2}{1}$$
$$\frac{\% \text{ B in Compound II}}{\% \text{ B in Compound I}} = \frac{50\%}{75\%} = \frac{2}{3}$$



Thus the ratios are in whole number multiples, as predicted by the Law of Multiple Proportions."

Grade both of these statements as correct or incorrect and write the student an appropriate note of comment, criticism, or explanation. If any mistake has been made, the student should be made to understand the nature of his error.

---

Several compounds of oxygen and nitrogen are known to exist. Two of these have the following percentage compositions:

	<u>% Nitrogen</u>	<u>% Oxygen</u>
Compound I	46.7	53.3
Compound II	22.6	77.4

- (a) Calculate how many grams of oxygen combine with 1 gram of nitrogen in each case.
- (b) What is meant by the "Law of Constant or Definite Proportions?" In what way is this law illustrated by the above data?
- (c) Examine the above data to see whether or not they illustrate or conform with the "Law of Multiple Proportions", and explain your conclusions.
- (d) State in your own words, giving numerical examples from your own measurements as needed, what the "Fasteners and Rings" experiment had to do with the chemical "Law of Multiple Proportions."

---

(a) By citing specific numerical examples, illustrate what is meant by the terms "Law of Definite Proportions" and "Law of Multiple Proportions."

(b) Explain in your own words why it is generally felt that these two observed regularities lend more support to a corpuscular or "building blocks" view of the structure of matter than to a continuum model.

---

Two substances A and B appear to interact with each other. An investigator measures the composition of two different samples of the product of the interaction, obtaining the following results:

Sample #1	35.8%	A
Sample #2	20.4%	A

The investigator would like to know whether or not true chemical compounds are being formed in the interaction, but he has no additional amounts of A and B with which to perform further experiments to see whether the Law of Definite Proportions is being obeyed. He recognizes that the compositions listed above might represent two different chemical compounds rather than a failure to obey the Law of Definite Proportions. He therefore analyzes the data to see whether they are consistent with the Law of Multiple Proportions.

Analyze the data yourself and interpret the results, indicating what conclusions the investigator might draw.

---

(a) Report your own data for Tables 10.6.1 and 10.6.2 in Experiment 10.6.

(b) In your own words, explain the point of this experiment: what is its relevance or connection to the invisible world of atoms and molecules?

(c) Explain what is meant by the term "Law of Multiple Proportions" (as it applies to measurement of composition of actual substances, not the artificial illustrations provided by the fasteners and rings). From the information you have encountered in various problems in Chapter 10, give a specific example of a pair of compositions that obey this law.

---

An experiment involving nuts (N) and bolts (B), which was performed to illustrate some properties of compounds, yielded the following two sets of data (The experimenter prepared three samples of each compound):

	mass of B in grams	mass of N in grams
Compound I	560.	180.
(formed by attaching	280.	90.
1 nut to each bolt)	420.	135.
Compound II	140.	90.0
(formed by attaching	84.0	54.0
a certain number of	532.	342.
nuts to each bolt)		

(a) Show clearly how the experimental results may be used to illustrate  
1. the Law of Definite Proportions; 2. the Law of Multiple Proportions.

(b) How many nuts are attached to each bolt in Compound II? If the formula for Compound I is  $NB$ , write the formula for Compound II.

It is established that oxygen atoms have 1.33 times the mass of carbon atoms. Suppose we have 100g of oxygen. How much carbon should we weigh out in order to have the same number of atoms of carbon as we have of atoms of oxygen? Explain your reasoning. (Note that, at this stage, we have no idea how many atoms of oxygen are present in 100 g of the gas.)

---

The molecule of the poisonous gas carbon monoxide is known to be binary (i.e. having the formula CO with one atom of each element forming the molecule). The composition of the gas is known to be 42.9% carbon.

(a) Suppose we have two containers, one with 42.9g of carbon and the other with 57.1g of oxygen. How do the number of atoms in the two containers compare with each other? Explain your reasoning.

(b) Which atom has the larger mass — an atom of carbon or an atom of oxygen? Explain your reasoning.

(c) Calculate the ratio of the mass of a carbon atom to the mass of an oxygen atom. Explain your reasoning.

---

It has been established that atoms of copper (Cu) have 2.37 times the mass of atoms of aluminum (Al).

Suppose we weigh out 100g of copper. How much aluminum should we weigh out in order to have a sample of aluminum containing the same number of atoms as our sample of copper?

Make the calculation, and explain your reasoning.

---

## Chapter 11

### The Annual Motion of the Sun

#### 11.1 Content

This chapter, like Chapter 6, is more a detailed study guide than an expository text. Students should work through it in sequence with careful attention to all questions and problems.

It is desirable to maintain this as principally an extra-class activity rather than allowing it to become part of the regular class and laboratory work. Students are not likely to distribute their time and efforts accordingly, however, without some prompting and guidance from the staff.

Study Guide D on calculation of the size of the earth is designed as a written problem to be handed in. It lends itself particularly well to this purpose.

If access to a planetarium is available, this is an excellent point for a second planetarium visit. This time the entire session should be devoted to a very slow recapitulation of all aspects of the annual motion of the sun — mapping out the ecliptic, emphasizing the non-coincidence of the equatorial and ecliptic planes, running through the complete diurnal sequence (noting positions of rising, setting, crossing of the celestial meridian, and comparative lengths of day and night) as the sun shifts along the ecliptic, observing what happens at the special cases of the solstices and the equinoxes, shifting the latitude of the point of observation in the northern and southern hemispheres and to the poles, noting where the full moon would be observed to rise when the sun is at the solstices or the equinoxes, etc.

#### 11.2 Test and Examination Questions

Suppose the sun occupied a fixed position at the north celestial pole. Describe what a 24-hour period would be like at the latitude at which you live; what path would the sun be observed to follow in the sky? what would be the intervals of daylight and darkness? what would you expect to see in the way of diurnal motion of the stars? (Explain your answers in each case.)

---

Suppose the sun remained permanently at a point on the celestial equator. What would you expect to observe in the way of diurnal motion of the sun and stars (over a 24-hour period) if you were located exactly

at the north celestial pole?

---

Describe in your own words several observations that lead to the conclusion that, from the point of view of a terrestrial observer, the sun keeps shifting its location against the background of the fixed stars. (Explain how the observations lead to this conclusion.)

---

Give an operational definition of the terms "ecliptic," "vernal equinox," "winter solstice."

---

Give an operational definition of the term "Tropic of Cancer."

---

People frequently say rather vaguely, on the basis of something remembered but never understood, that the "earth is tilted." (a) Argue that, as it stands, this is a meaningless statement. (b) Indicate how you might lead a person to understand what is involved and to make a statement which is complete and correct.

---

Describe the behavior of the sun that would be observed from a location at  $66.5^{\circ}$  north latitude over a 24-hour period at the summer solstice; i.e. what track would the sun follow through the sky?

---

Given the following observed facts: (a) the angle between the planes of the ecliptic and celestial equator =  $23.5^{\circ}$ ; (b) the latitude of observation =  $47.5^{\circ}$  N.

Drawing large, clear diagrams and explaining your line of reasoning carefully, find the noontime elevation above the horizon of the sun when it is (a) in the summer solstice, (b) in the winter solstice at the indicated latitude of observation.

---

The following are some observed facts concerning the location of the moon relative to the ecliptic: In general, the moon is not located directly on the ecliptic. In the course of a month, the moon attains a largest angle of about  $5^{\circ}$  above the ecliptic and about two

weeks later it is at a largest angle of about  $5^\circ$  below the ecliptic.

- (a) What do these observed facts tell us about the tilt of the moon's orbit relative to the plane of the ecliptic?
- (b) How many times each month does the moon cross the ecliptic? (Explain your answer.)
- (c) Lunar and solar eclipses occur only at one of those times when the moon happens to be crossing the ecliptic. Explain.
- (d) Suppose that the moon crosses the ecliptic when it is in the first-quarter phase. Would you expect either a lunar or a solar eclipse to occur? Explain your answer.

---

The very bright star Sirius (sometimes called the Dog Star) follows the constellation of Orion (the hunter) through the southern sky. At a latitude of  $48^\circ$  N Sirius is observed to cross the local celestial meridian at an elevation of about  $22^\circ$  above the southern horizon. The following figure shows a cross section of the earth through the local terrestrial meridian, and a  $48^\circ$  N latitude location is labelled A.

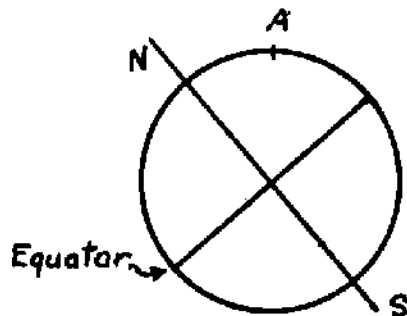

- (a) At location A on the diagram, draw and label the horizontal and vertical lines.
- (b) Draw and label a ray of light arriving at point A from Sirius using the information given above concerning the elevation above the horizon when the star crosses the local celestial meridian.
- (c) By adding appropriate lines to the diagram, determine whether or not Sirius is visible from the North Pole. If it is visible, is its elevation above the horizon greater or smaller than its elevation at point A? Explain your reasoning briefly.
- (d) By adding appropriate lines to the diagram, determine whether or not Sirius is visible from a point on the equator. If it is visible, is its elevation above the horizon greater or smaller than its elevation at point A? Explain your reasoning briefly.
- (e) During the period June, July, and August, Sirius is not visible at all at  $48^\circ$  N latitude at any time of night. How do you interpret this observed fact?

By adding appropriate lines to the diagram below, show how an observer at point A could determine his latitude:

(a) by observation of the North Star,

(b) by noontime observation of the sun when the sun happens to be passing through an equinox.

(Label each line that you draw, indicating its meaning or significance. Explain your reasoning in each case, indicating clearly what angles you would measure and how these angles are related to the observer's latitude.)

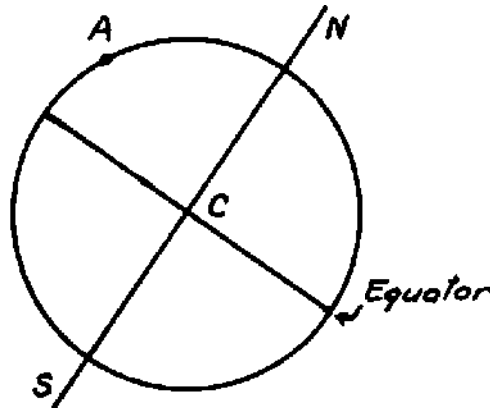

(c) Why is it that the observation of the North Star could be made at any time it happened to be visible while the solar observation must be made at noon?

---

Suppose that on a particular day you make observations of the shadow of a vertical stick from some time in late morning into early afternoon. Suppose further that a friend of yours makes exactly similar observations on the same day at a location about 2000 miles due east of your own. Do you expect the two records to differ in some way or to be essentially similar? If you expect them to differ, describe what difference you anticipate. In either case, explain your line of reasoning and indicate what additional prior knowledge you are bringing to bear on the problem.

---

In the world as we know it, it is a fact that the ecliptic and the celestial equator do not coincide, and we have been visualizing various aspects of the annual celestial change in the light of this observation.

For the sake of this problem, let us imagine a different world: suppose the ecliptic and celestial equator did coincide. In the following question you are asked to predict how we would see the sun behaving under these circumstances from various points of observation on the earth.

Assuming that the ecliptic and the celestial equator coincide:

(a) On the diagram below show the position of the sun relative to the earth by drawing a set of light rays coming to the earth from the sun. (Remember that the sun is extremely far away.)

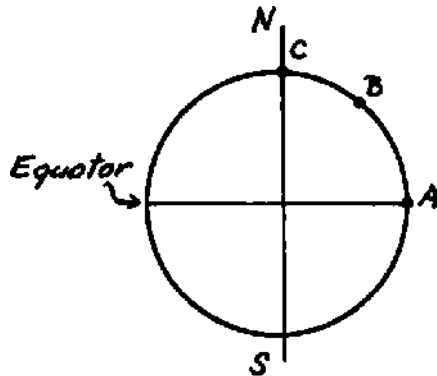

The following questions pertain to observers located at A, B, and C.

(b) Where would we see the sun rising, setting and crossing the local meridian at the three locations A, B, and C? How would these positions of rising, etc. change during the year?

(c) Describe the relative lengths of daylight and darkness at the three locations A, B, and C. How would these change during the course of the year?

---

Imagine that you are looking straight down on a piece of paper at the shadow of a vertical stick on a sunny day. Consider each of the following days:

- (1) the day of the autumnal equinox (about September 21)
- (2) a day in early November
- (3) the day of the winter solstice (about December 21).

For each of these days, make a separately labeled diagram of the shadows you would expect to see:

- (a) shortly after sunrise
- (b) at local noon
- (c) shortly before sunset.

Be sure to label the cardinal points (N, S, E, W) on each diagram and identify the day as (1), (2), or (3). Label each shadow as occurring at (a), (b), or (c).

Indicate clearly how the relative lengths and directions of the shadows vary during a particular day and from day to day. You should have three diagrams, one for each of the days listed.

---



(a) In the diagrams below, show the position of the sun relative to the earth by drawing the direction of the sun's rays on the earth on the four dates indicated. (Draw at least six rays to the right of each diagram of the earth.)

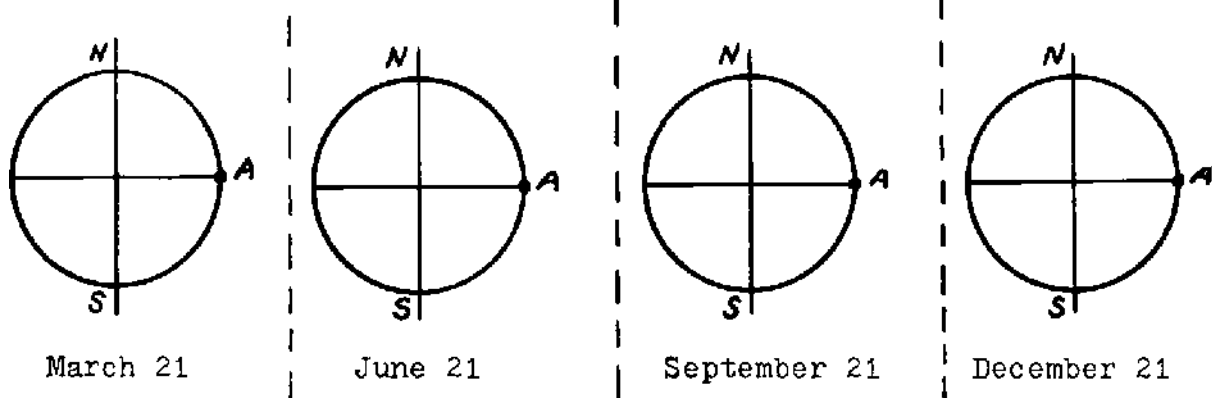

The following questions pertain to an observer A on the equator:

- (b) Describe where the sun is located at noon relative to the observer's zenith on the four dates indicated, i.e. is the sun at the zenith? north of the zenith? south of the zenith?
- (c) Describe where the sun rises and sets on the four dates indicated, i.e. does the sun rise due east? north of due east? south of due east?
- (d) Describe the relative lengths of daylight and darkness on the four days indicated.

Suppose we adopt the generally accepted model of our solar system: Suppose the earth revolves around the sun in the time we call one year, and it spins on its own axis producing night and day. However, unlike the usual model, let us imagine what would happen if the earth were to revolve around the sun with its axis always tipped towards the sun, as illustrated in the diagram below. The questions that follow pertain to the observations the inhabitants of such a tilted earth would make.

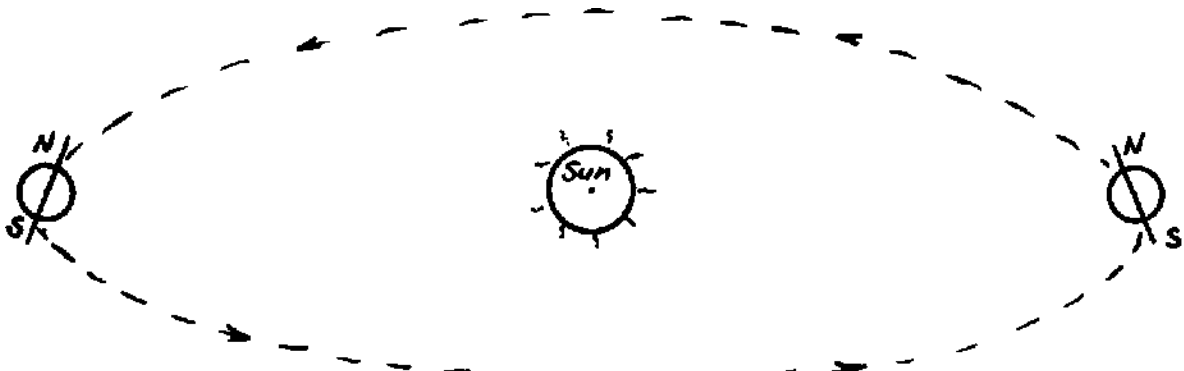

Indicate whether you regard each of the following statements as true or false by circling the corresponding letters T or F. You may, if you wish, also include a comment under each statement explaining your choice.

- |   |   |   |
|---|---|---|
| (a) Under these circumstances it would always be day at the north pole, and night at the south pole.  | T | F |
| (b) At our latitude days would always be longer than nights during all seasons of the year.   | T | F |
| (c) It would always be winter in the southern hemisphere.   | T | F |
| (d) The positions of sunrise and sunset will not change with the seasons regardless of where one is located on the earth.   | T | F |
| (e) The sun would always cross the same point on the local meridian at noon. (Its elevation above the horizon at noon would not change from day to day.)  | T | F |
| (f) Instead of there being a fixed pole star, the location of the celestial pole would keep changing during the course of the year (i.e. it would swing through a circle against the field of stars). | T | F |
| (g) The ecliptic, i.e. the apparent path of the sun against the field of stars, would not intersect the celestial equator, and from our point of view would lie entirely above the equator.           | T | F |

---

Explain the observed difference in length of days during the year in terms of a model in which the sun moves around the earth. (Think about what you would see the sun doing if you observed it all year from one location on the earth.)

---

We have examined two different models for the solar system — the geocentric and heliocentric — and have found that both are very consistent with almost all our observations of the sky.

Account for the following phenomena by explaining them in terms of each of these two models:

- (a) Seasons on the earth with the observed difference in length of days.
  - (b) Rising and setting of the stars with the observed approximately 4-minute earlier rising each night.
-

The following data applied in March 1976: the sun passed through the vernal equinox on 20 March. In the following questions, let us think of the sun as being close to the vernal equinox throughout the time interval under consideration.



(a) On 18 March 1976 the moon rose between 9 and 10 PM, i.e. about 3 hours after sunset. On the diagram at left, show what you expect this phase of the moon to have looked like as it rose. (Label the bright and dark portions.) Explain briefly how you arrived at the picture you indicate.

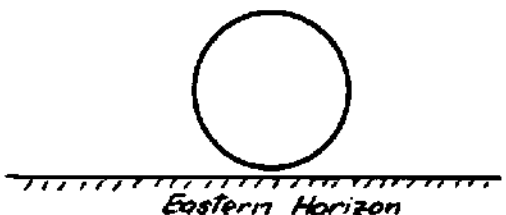

(b) On the diagram at left, show what the moon must have looked like when it rose one week earlier than in Part (a), i.e. around 11 March. (Label the bright and dark portions.) Explain briefly how you arrive at your picture.

(c) At approximately what time relative to sunrise or sunset would you expect the moon in Part (b) to be rising? Explain your reasoning.

(d) Approximately where along the ecliptic was the moon located when it was full in March 1976? At what points along the horizon must it have risen and set? Explain your reasoning.

(e) Return to the diagrams in Parts (a) and (b). Use the letter E to mark the due east point on each diagram. (It is not intended that you establish a numerically precise location; simply use this as a device to indicate whether you expect the moon to be rising north of east, south of east, or due east in each instance.) Explain briefly how you arrived at your conclusions.

---

## Chapter 12

### Describing Motion I

#### 12.1 Content

It is well known that students have grave difficulty with elementary kinematics when they are suddenly exposed to this subject in introductory physics. There seem to be two sources for this difficulty: (a) the intrinsic abstractness of concepts such as velocity and acceleration with the abstractness still further intensified through the vertical sequence in which instantaneous velocity evolves from average velocity and acceleration evolves from instantaneous velocity; (b) the role of division and other aspects of arithmetical reasoning in forming and using the kinematic concepts.

One of our reasons for having started this course with properties of materials and chemical phenomena rather than with kinematics is the fact that, by first giving students the opportunity to overcome their fear of arithmetical reasoning through practice with relatively concrete concepts such as density, solubility, chemical composition, and  $\pi$ , we can help them confront the abstractness of kinematics without their simultaneously being overwhelmed by the concomitant arithmetical reasoning.

We are satisfied that this strategy has proved effective and that the students develop a far better grasp of kinematics, with far less stress and strain, than is the case in the more conventional physics sequence. One must not regard this as a magical solution, however. The abstractness of the concepts is still formidable — particularly the distinction between velocity and acceleration. Students will bandy the words around quite freely and give one the feeling that they are beginning to understand, but then, in some specific physical situation (a ball thrown upward, for example), it will suddenly emerge that they do not really discriminate between velocity and acceleration and still have the two concepts nebulously intertwined. Yet this discrimination is absolutely essential if they are to understand the law of inertia and make the transition from the Aristotlean view with which we are all born to the modern scientific view of motion. Without making this transition they can never genuinely understand why we hold the view that the earth revolves around the sun.

The treatment in this text is designed to lead the students very gently and carefully into the abstractions of kinematics. Great care has been taken to develop ideas first and names afterwards. Intuitive terms such as faster, slower, speeding up, slowing down are used from the beginning but the words "velocity", "speed", "acceleration" are reserved as technical names and are not enunciated until after the respective concepts have been developed and discussed operationally.

We have found that Section 12.3 (in which students, after having been shown how flash photographs are made, predict the appearance of flash photographs of very simple motions before actually making photographs of their own) forms a very helpful and powerful preliminary to the subsequent work. The pencil-and-paper activity involved in this section can very fruitfully take place as a group activity under the leadership of a staff member who first demonstrates how flash photographs are made and then describes or exhibits the various motions for which the students might sketch predicted flash photographs.

Contrary to what one might initially think, it is not desirable to start off this pencil-and-paper activity with uniform motion. Students do not understand that words such as "uniform" and "constant" require operational definition in this context, and they do not really know what these words mean. We have found it much better to start in with speeding up and slowing down and then recognize the case of neither speeding up nor slowing down, with its equal spacing between images, as that simple, special case which will be called "uniform."

During this group discussion, we have frequently raised Question 12.12.8 (the expected appearance of a flash photograph of an object in free fall) without carrying it through to an answer, leaving the students with a question to be thought about and investigated. It is surprising how many students believe this to be a case of uniform motion. It is best that they eventually find out for themselves.

This chapter is deliberately confined to the concept of average velocity. The last section raises the questions that lead one to instantaneous velocity, but this concept and the concept of acceleration are both dealt with in the next chapter.

The multiplicity of interwoven contexts invoked in this chapter (flash photographs, numbers, words, and symbols; translation back and forth to  $s$  vs  $t$  graphs) is part of the teaching strategy we have found to be effective. The richness of the matrix is profoundly important; being able to see and say the same thing in several different ways is one of the best roads to understanding. In addition, the sketching and interpretation of graphs is still a very necessary exercise for most students. It will be found that they are still insecure and deficient in this capacity despite the exposure provided in earlier chapters. Very substantial emphasis should be placed on Section 12.7 C (students do not correctly identify on an  $s$  vs  $t$  graph the lengths that represent change of position and time intervals respectively and believe that the distance travelled by the body is the slant length along the straight line or curve itself) and on Problem 12.12.1. In the latter, the intimate muscular sense invoked in interpreting an  $s$  vs  $t$  graph by executing the motion with one's own hand plays a vital role in the learning process (pun intended). In a Piagetian framework, this might be viewed as a way of leading the student into a process of self-regulation and equilibrium at a new level of formal reasoning.

One of the gravest and most gratuitous pedagogical mistakes frequently made in the teaching of elementary kinematics is to start off by defining speed or velocity as "distance over time" (what distance? what time?) and denoting this by some abbreviated symbolism such as  $s/t$ . A little while later, without anything being explicitly said to the

learner — who already has enough trouble on his mind with the abstractions and the arithmetical reasoning —  $s$  and  $t$  suddenly become position numbers and clock readings rather than distances and time intervals. Furthermore, even when position numbers are defined, it is rarely explicitly pointed out to students that, unless the motion under consideration is monotonic,  $\Delta s$  only indicates change of position and is not equal to the distance travelled by the body.

In the treatment of this chapter,  $s$  never represents anything but a positive number, and  $t$  represents only clock readings and never a time interval. Our experience indicates that teachers will find this helpful providing they do not unwittingly violate the idea and regress to the travesty widely perpetrated in the textbooks.

## 12.2 Experiments and Equipment

Experiment 12.4, the making of flash pictures of uniform and accelerated motions, can be carried out in a wide variety of ways. The text has not been frozen around any one particular way in order to leave as much latitude as possible for the use of whatever equipment is available in a given course. The ideal way is to allow each pair of students to make their own polaroid photographs, including making a few mistakes in the process. There is good reason for their being aware that mistakes and the encountering of difficulties are not sinful but, rather, are normal experience for all of us in all scientific work. Since polaroid camera models keep changing in details of setting and operation each teacher will have to prepare a brochure on the use of the particular camera or cameras he has available in his own laboratory.

The moving objects for this experiment can be gliders on air tracks, self-propelled toys (such as the Project Physics bulldozer), rolling carts, or even rolling balls. Timing can be provided by strobe lights, rotating shutters, or the Project Physics blinky (a simple neon lamp relaxation oscillator) mounted on the moving object. We have confined our own laboratory work principally to the rotating shutter and the blinky. If the rotating shutter is used (particularly if it has multiple openings), students should be given a few numerical exercises in calculating the exposure rate.

If photographic equipment is not available, adequate experiments can still be performed with rolling carts, ticker tape, and the PSSC style bell timer.

If the amount of equipment is very limited, it might be necessary for a staff member to make the pictures and provide them to the students. This is the least desirable approach. If it must be used, students should at least see how their photographs were obtained. Actually, if the course operation is reasonably individualized and the students are to some extent spread out in their pace through the material, two photograph set-ups are adequate for a section of as many as 30 to 40 students working in pairs.

### 12.3 Demonstration

At about this point, preferably after generation of the concept of uniform velocity, we have found the following demonstration to play a very fruitful role:

A large (6 ft by 4 ft or larger) piece of plate glass is levelled up on a laboratory table, and a 30 to 50 lb block of dry ice is allowed to sail back and forth on the glass plate. Each student is asked to play with the block—hands-on, with good work gloves.

Students are led to observe the character of the motion, to recognize it as uniform and rectilinear, and to note that it does not run down appreciably as do most familiar motions. They are asked what they must do to make the body speed up gently and keep on speeding up. (They are invariably astonished at how small a push is required to impart appreciable motion and they do not expect to have to run along faster and faster with the object in order to keep on pushing and speeding it up.) They are then asked what they must do to make the body slow down and keep on slowing down, as well as what happens as the same action that gently slows the body down continues to be exerted indefinitely. They are then asked what they have to do to change the direction of the motion of the body, preferably without changing its speed.

This is a "fun" demonstration, deeply impressive to all. The law of inertia is not explicitly enunciated at this point. Concentration is exclusively on operational description of what is actually observed. From here on, however, students are reminded of this demonstration at every relevant opportunity, until the law of inertia is formally enunciated in connection with the discussion of Galileo's contributions to the study of motion.

The capital investment in the piece of glass and the cost of the expendable block of dry ice unfortunately make for a relatively expensive demonstration. One can, of course, achieve similar results with gliders on an air track, pucks on an air table, or dry ice pucks on smooth surfaces, but the hands-on experience with these less massive objects is several orders of magnitude less dramatic and impressive than it is with the block of dry ice. It is hard to equal the impression conveyed by the majesty with which the block of dry ice sails with slow but undiminishing speed on the glass plate.

### 12.4 Test and Examination Questions

Following is a flash picture of a ball rolling in a straight line.



(a) Label crucial points with letters A, B, C, and describe the motion of the ball in words, identifying intervals of uniform velocity, slowing down, speeding up, etc.

(b) Sketch an  $s - t$  diagram of the motion, indicating the location of points corresponding to A, B, C, . . . .

The figure shown below is a position versus time graph of the motion of a car.

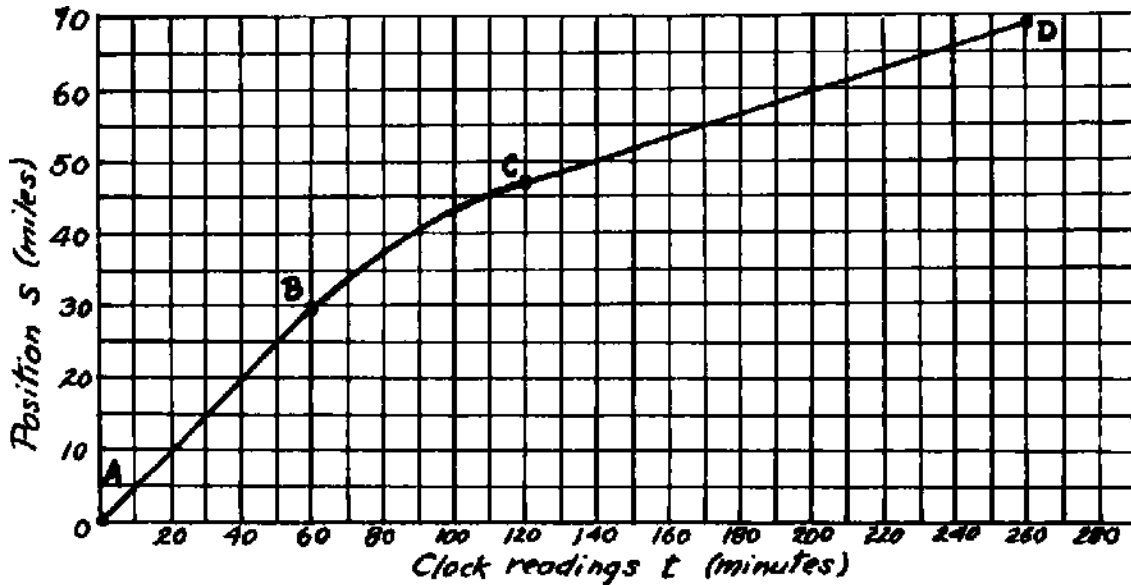

(a) Interpret the graph in words, describing what happens during the various sections of the curve. What would you see the speedometer needle of the car doing during sections AB, BC, and CD? When is acceleration involved if at all? Are there any uniform velocities? If so, calculate these velocities starting with the definition in symbols and showing all the details of your calculation.

(b) Draw a "flash picture" of the motion of the car from A to D.

The following graph shows the  $s$  vs  $t$  history of the rectilinear motion of a body. Translate this history into words, describing what the body is doing in each of the indicated intervals AB, BC, etc. Extract all the information the graph contains, paying attention to matters such as direction of motion, speeding up, slowing down, uniform velocity, etc.

What was the average velocity of the body over the time interval between clock readings  $t_1$  and  $t_2$ ? Explain your reasoning.



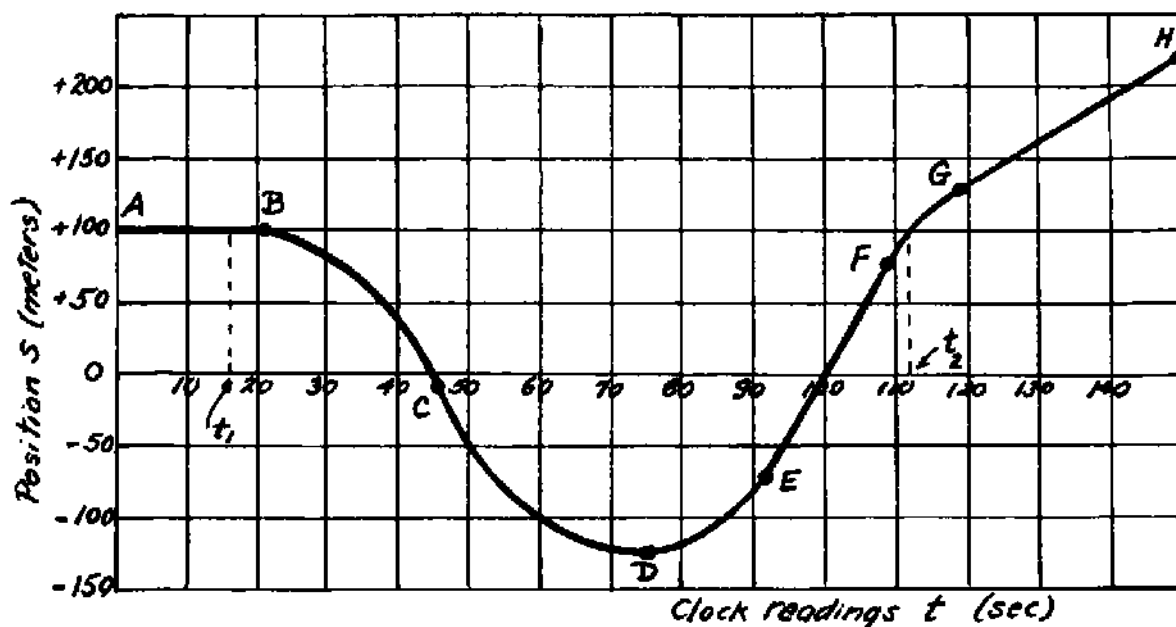

(a) In the figure below a ball rolls on a level surface AB according to the flash picture indicated. Suppose it continues down the hill BC and along the level surface CD. Complete the flash picture for the region BCD.

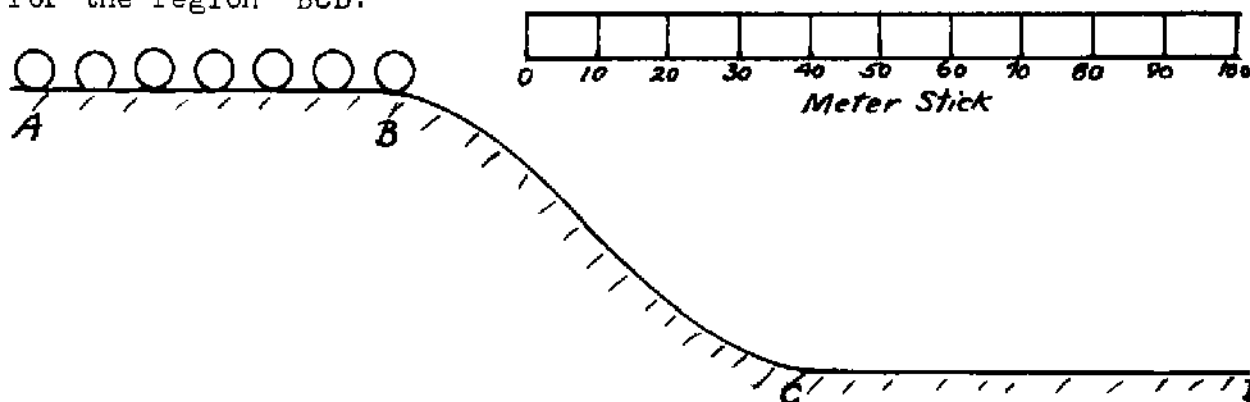

(b) Choose a reasonable numerical value of flash rate (that is, a reasonable number of flashes per second) and calculate the numerical value of the average velocity of the ball in the region CD. Express your results in the units of centimeters/second and explain the calculation in your own words.

(c) If the ball continued moving on level ground at the average velocity you calculated in part (b), how long would it take the ball to roll 250 centimeters? Explain your arithmetical reasoning in words without manipulating an algebraic formula.

(d) Make up a numerical problem (using legitimate and realistic numbers) involving mass, volume, and density in which the arithmetical reasoning follows exactly the same line as that of part (c). Carefully explain the solution to your own problem, showing the reader that the line of reasoning is indeed the same.

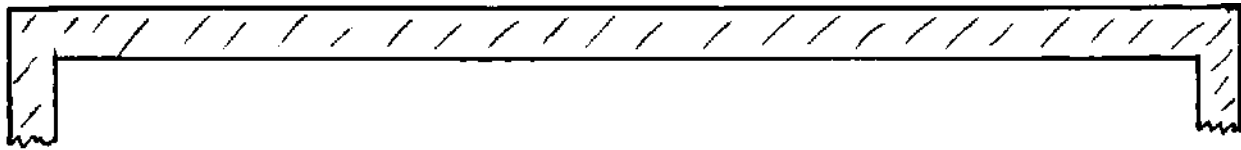
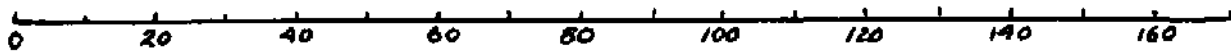

(a) On the diagram above sketch a flash picture of a ball rolling on the table; the ball moves from left to right, first slowing down and then speeding up. The flashes occur at a regular or uniform rate.

(b) Calculate the average velocity of the ball between any two images you choose on your flash picture.

You must first decide on a flash rate and the units of the scale above the table (inches, feet, meters, etc.). Indicate your choices of scale units, flash rate, and the two images between which you choose to calculate the average velocity clearly on the diagram.

Now calculate the average velocity for your chosen interval, starting with the definition of average velocity in symbols and show all the details of the calculation.

(c) Sketch a position versus clock reading graph of the motion of the ball.



A car moves with uniform velocity from position A to position B, six miles away. The car leaves position A at 1:00 pm, and arrives at position B at 1:15 pm. The vehicle then suddenly reverses direction and travels towards position A with a uniform velocity of -8 miles/hour. At 1:45 pm. the car arrives at position C which is to be determined.

(a) What is the final position C of the car, relative to position A? Indicate the details of your calculation.

(b) Sketch an s - t history of the motion, marking points corresponding to the car being at A, B, and C.

(c) What is the average velocity of the car from position A to position

B? From B to C? Using appropriate symbols, and showing all details of your calculations, determine the average velocity from A to C.

---

(a) A car left home and travelled for 2 hours and 15 minutes, at which time it was located 78 miles from home. If the car continues at the same average speed, how much more time will it take to arrive at a point 100 miles from home?

Show all your calculations and describe your reasoning fully. Do not manipulate formulas; explain all arithmetical reasoning in the manner established in our work with density, circles, etc.

(b) Make up a density problem in which the information given and the sequence of reasoning is parallel step by step to the problem given above.

---

The speed of light is known to be 186,000 miles/sec. Let us carry out the following calculations to two significant figures, rounding this value of the speed of light off to 190,000.

(a) Express the speed of light in the power-of-ten notation.

(b) Light from the sun requires about 8 minutes to travel to the earth. (How many seconds are there in 8 minutes?) Calculate how far the sun is from the earth. Use the power-of-ten arithmetic and explain your arithmetical reasoning in words. (Do not just manipulate a formula.)

(c) The average distance from the earth to the moon is about 250,000 miles. How long does it take a pulse of light to travel from the earth laboratory to a reflector on the moon? Use power-of-ten arithmetic and explain your reasoning in words. (Do not just manipulate a formula.)

(d) Here is a question involving density. Read it, but you are not required to answer it.

"The density of copper is 8.9 grams/cubic centimeter. The volume of a copper bar is 50 cubic centimeters. What is the mass of the bar?"

Here is the question you are to answer: Is the question involving the density of copper more like the question about the earth and sun (part (b)) or more like the question about the earth and the moon (part (c))? Explain why you made the choice you did.

---

You have probably at one time or another seen a "speeded up" motion picture of a flower opening up before your eyes or a plant growing. This speeding up effect is known as "time lapse" photography. In this problem you will be asked to make your own calculations and judgments as to the rate at which pictures must be taken to achieve the "speeding up" effect.

(a) Suppose we want to present on the screen the complete opening of a flower (daffodil? rhododendron? camelia? anything you like) from the full bud to the fully opened flower.

You must first decide on how long you want this show to last on the screen. Support your choice of this time interval.

(b) In the movie projector, the illusion of motion is achieved by flashing successive pictures on to the screen at the rate of about 20 pictures per second.

How many pictures will you need in order to present your entire speeded up version of the opening of the flower? About how long does it take the flower to open? (You must make your own reasonable estimate of this duration.)

(c) Time lapse photography is carried out by setting up a movie camera focussed on the object (flower, in this case) and equipping it with a trigger that makes the camera take successive shots on successive frames of film at intervals of seconds, minutes, hours — whatever one wishes — instead of running the film through at high speed as in ordinary movie making.

To obtain your movie of the flower, what time lapse (i.e. what time interval between successive shots) will you want to set? Carry out your calculation, explaining all steps briefly, and present your final result.



## Chapter 13

### Describing Motion II

#### 13.1 Content

This chapter continues the development of the kinematic concepts begun in Chapter 12. It consists principally of questions, problem work, and pencil-and-paper experiments.

The concept of instantaneous velocity is possibly the most subtle aspect of the entire structure of kinematics, and the development is therefore carried out very slowly, with many illustrations, interpretations, and attempts to connect it with familiar experience.

The precept of "idea first and name afterwards" is carefully adhered to in the development of the concept of acceleration, and a steady effort is maintained to keep the student both intuitively and linguistically aware of the distinction between velocity and acceleration. Particularly important in this context are Experiment 13.4, Problem 13.5.2, and Questions 13.5.5 and 13.5.6. Also important is the insistence on the locution "velocity at an instant" as opposed to "for an instant" (Question 13.3.3).

The emphasis on interpretation of  $v - t$  diagrams in Sections 13.6 and 13.7 has several motivations: (a) insuring firmer grasp of the kinematic concepts by enriching the entire matrix in which they are applied and manipulated; (b) continuing the important exercise of translating symbols into words and words back into symbols via the interpretation of graphs; (c) paving the way for derivation of the kinematic relation  $\Delta s = \frac{1}{2} a (\Delta t)^2$  by interpretation of the area under the  $v - t$  graph.

#### 13.2 Equipment

Same equipment as that used in experiments of Chapter 12: obtain multi-exposure photograph of an accelerated motion.

#### 13.3 Test and Examination Questions

Since the beginning of the course we have been using the term "operational definition" in connection with our creation of scientific concepts. Describe in your own words what is meant by the term, illustrating your description through a specific example for the case of "acceleration." (Giving the operational definition only is not sufficient, however. Be sure to describe the general idea of operational

definition first and then show that your specific example illustrates the general idea.)

---

Give a careful operational definition of the term "average acceleration." In the process, be sure to make clear why it is impossible to generate the concept of acceleration without having first invented the idea of instantaneous velocity.

---

Treat the following as problems in direct arithmetical reasoning without recourse to formulas:

(a) A car moves with a uniform acceleration of 5.0 ft/sec/sec, changing its velocity from 12 ft/sec to 90 ft/sec. In what interval of time does the indicated change in velocity occur? (Explain the arithmetical reasoning carefully in your own words.)

(b) Make up a problem in some other context (density, circles, concentration of solutions, etc.) in which the line of reasoning is parallel to that of the problem in part (a). Give the solution to your problem, showing the parallelism of reasoning as clearly as possible. (The point is to make up a problem in which the reasoning with respect to multiplication, division, etc. is exactly parallel. Do not try to invent a problem in which density or concentration is moving, changing or accelerating.)

---

The quantity we have called "average velocity" ( $\bar{v}$ ) in rectilinear motion is defined by the following statement:

$$\bar{v} = \frac{s_2 - s_1}{t_2 - t_1}$$

We have encountered the following cases of straight line (rectilinear) motion: uniform velocity, uniformly accelerated motion, non-uniformly accelerated motion. In which case or cases is the above concept of average velocity applicable? All three cases? One or two? none? Explain your answer.

---

We throw a ball upwards and it leaves our hand at the instant that the clock reads zero. At this instant it has an upwards instantaneous velocity of 96 ft/sec. The acceleration of the bodies that are moving freely up or down is known to be 32 ft/sec/sec (32 ft/sec<sup>2</sup>), slowing down if rising and speeding up if falling. Fill in the table below giving the instantaneous velocities that the ball would have at the

successive clock readings. Show with an arrow which way the ball is going at each one of the specified instants as illustrated by the first entry.

Clock Readings (seconds)	Instantaneous Velocities (feet/second)
0	96 ↑
1	
2	
3	
4	
5	
6	

(b) Interpret your table: When would the ball have been at the highest point in its upward flight? When would it have returned to the starting point?

Draw the velocity versus time graph of this motion using actual numerical scales on the axes.

Sketch a rough position versus time graph of this motion. This need only show the general shape; do not include the numerical values on the axes.

A particle moves with the velocity indicated on the graph below.

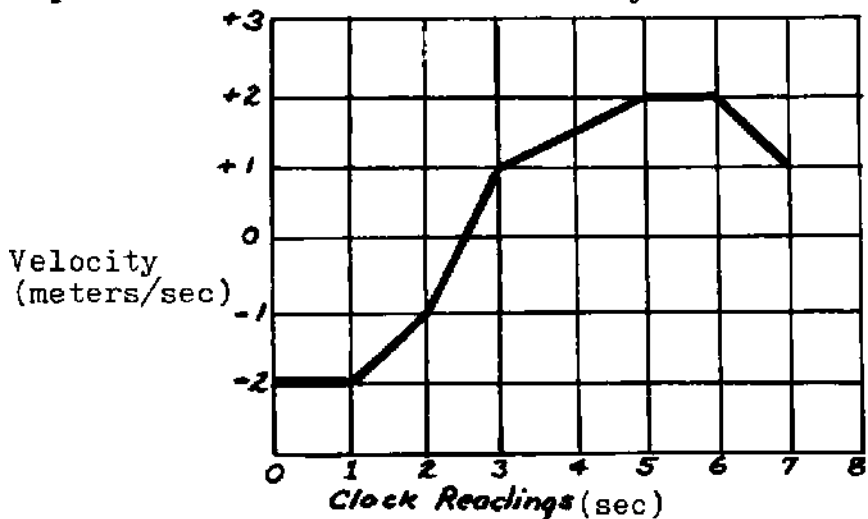

(a) Draw the position-time graph of the particle.

(b) Draw the acceleration-time graph of the particle.

Sketch  $s - t$  and  $a - t$  histories corresponding to the indicated  $v - t$  history of a rectilinear motion.

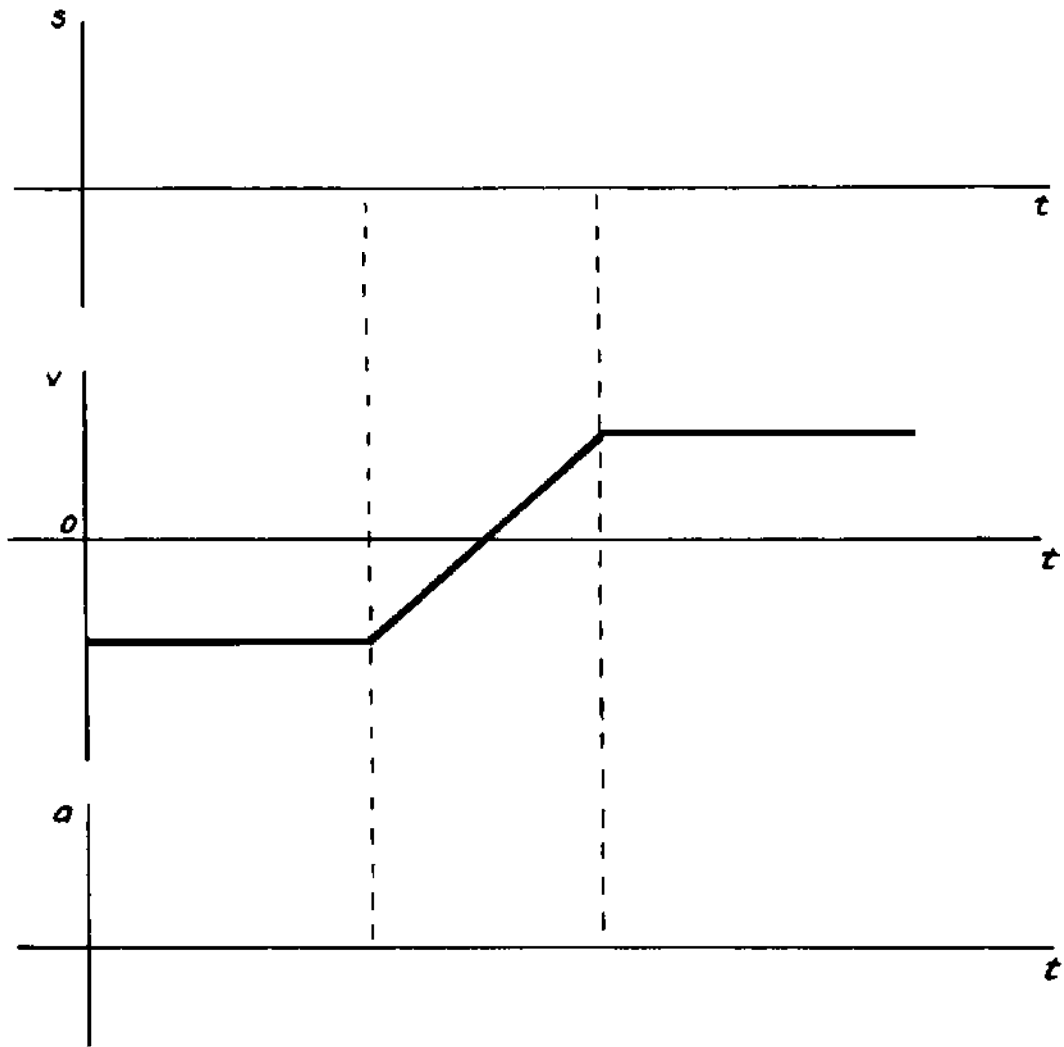

Points A and B are 10 meters apart. A particle begins at point A and moves toward point B. Its velocity history is shown on the diagram below.

- (a) At what time does the particle reach point B? That is, how long does it take the particle to cover 10 meters?  
Hint: To obtain an answer, you will need to construct a position - time graph.
- (b) What is the average acceleration of the particle between  $t = 0$  and  $t = 11$ ?
- (c) What is the largest instantaneous acceleration that the particle undergoes? Over what time interval does this take place?



(d) What is the smallest instantaneous acceleration that the particle undergoes? Over what time interval does this take place?

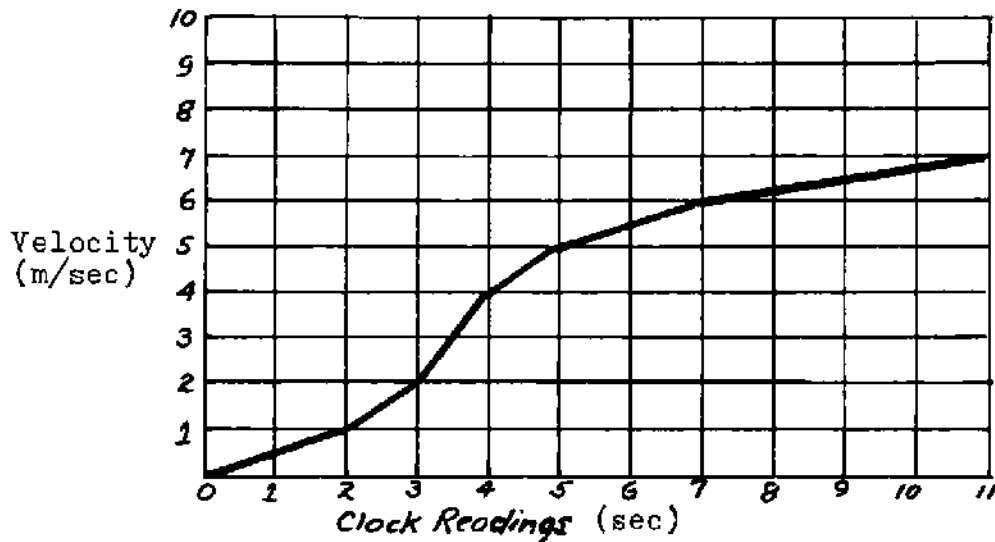

---

A car accelerates from rest to a velocity of 52 miles/hour in 16 seconds.

(a) What was the average acceleration? Explain your calculation very briefly.

(b) If the car were to accelerate uniformly at the value calculated in part (a), what change in velocity would take place in an interval of 8.0 sec? Explain your calculation.

(c) At this same acceleration, if the car has a velocity of +20 mi/hr at  $t = 4.0$  sec, what will be its velocity at  $t = 10.5$  sec? Explain your calculation.

(d) At this same acceleration, how long would it take to change velocity from +20 to +65 miles/hour? Explain your reasoning.

---

## Chapter 14

### Galileo's New Science

#### 14.1 Content

Except for optional Experiment 14.9 (repetition of Galileo's inclined plane experiments), this chapter is essentially a reading assignment in history and philosophy of science. As such, it can be assigned as reading to be done outside of class time. The context is profoundly important, however, from a general education standpoint; it is well worth one hour of class discussion.

The greatest difficulty for many students arises in the logical reasoning associated with the test of the hypothesis of uniform acceleration; the equation  $\Delta s = \frac{1}{2} a (\Delta t)^2$  is obtained from the theory of motion defined as uniformly accelerated;  $\Delta s$  and  $\Delta t$  values observed in actual motions may or may not obey this relation; if they obey the relation, we accept the hypothesis that the motion is uniformly accelerated; if they do not obey the relation, we reject the hypothesis. Very few students have had experience with syllogisms involving two steps of logical reasoning, yet we expect them to become thinking, reasoning citizens.

We will not achieve miraculous transformations with several exposures to logical reasoning in science, but there is a chance of producing a small statistical shift. It would be sad not to avail ourselves of the opportunity. Those students who do master the logic of this episode experience, as do the students who master arithmetical reasoning, a profound exhilaration and increase in respect for their own intellects. The value of this increase in self respect should not be underestimated.

Exercises with  $\Delta s = \frac{1}{2} a (\Delta t)^2$  and free fall are deliberately incorporated in the next chapter rather than in this one in order to maintain this chapter as principally a reading assignment.

The inclined plane experiment is left optional. It can be by-passed by slower students if this seems desirable. The experiment is a "fun" experiment for many students, however, particularly if they are given wide latitude of choice in how to perform it and if it is done in the spirit of retracing Galileo's work and thought.

#### 14.2 Demonstration

It has been our experience that almost none of our students have ever seen the "feather-and-coin-tube" demonstration of objects falling together in a vacuum. To them this is a novel and surprising experience—far from the commonplace it has become for most faculty members. The

demonstration is well worth performing — virtually a "must."

### 14.3 Test and Examination Questions

Starting with the definitions of acceleration and velocity, and taking  $a$  and  $t$  as the initially known or "given" quantities, derive the relation  $\Delta s = \frac{1}{2} a (\Delta t)^2$ . Indicate what situations this relation does apply to and what situations it does not apply to. Explain all steps of reasoning carefully in your own words.

---

(a) What was Galileo's hypothesis concerning the way in which instantaneous velocity changes in free fall?

(b) Describe in your own words how Galileo proceeded to test his hypothesis. Take particular care in outlining the logical reasoning that was involved, illustrating and making clear the "if . . . , then . . ." structure of the sequence.

---

Refer to your answer to Problem 14.7.4: Suppose that in making measurements on an accelerated motion, an observer obtains the following values:

$$(\Delta t)_A = 2.50 \text{ sec}$$

$$(\Delta t)_B = 10.0 \text{ sec}$$

$$(\Delta s)_A = 42 \text{ cm}$$

$$(\Delta s)_B = 126 \text{ cm}$$

Is the condition for uniformly accelerated motion satisfied? Explain your reasoning.

---

What is meant by the statement that "Galileo introduced an idealization into his view of the nature of free fall?" Use your response as a way of illustrating what is meant by the term "idealization" in this context.

---

Suppose we have a cart sitting on a smooth table at position  $s = 15 \text{ cm}$ , as shown in the diagram below.

At clock reading  $t = 0 \text{ sec}$  the cart is given a constant acceleration of  $16 \text{ cm/sec/sec}$  to the right.

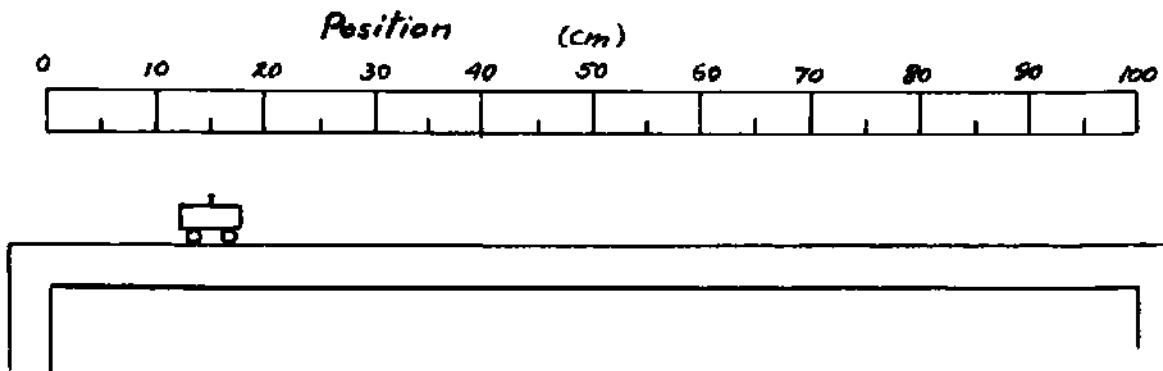

(a) Calculate the numerical values of the position of the cart at clock readings  $t = 1$  sec,  $t = 2$  sec, and  $t = 3$  sec. Show all the details of your calculations and explain your reasoning in your own words.

(b) Show on the diagram the position of the cart at clock readings  $t = 1$  sec,  $t = 2$  sec, and  $t = 3$  sec. Is this the flash picture you would expect for this motion? Why or why not?

---

(a) Consider the case of a ball thrown vertically upward. In the light of the concepts of motion that we have developed, what is the instantaneous velocity of the ball at the top of its flight? What is the instantaneous acceleration of the ball at the top of its flight? Give numerical values in both cases and justify your answers.

(b) Placing each graph sequentially below the preceding one, sketch  $s - t$ ,  $v - t$ , and  $a - t$  histories of the motion of the ball from the instant it leaves your hand to the instant it returns. (Just sketch the graphs qualitatively without attempting to provide numerical scales along the axes. Be sure, however, that the graphs are correctly lined up one above the other, i.e. that the  $v - t$  graph correctly shows what is happening at the corresponding clock reading on the  $s - t$  graph, etc.)

## Chapter 15

### Acceleration and the Law of Inertia

#### 15.1 Content

The first two sections of this chapter are essentially numerical exercises with  $g$  and free fall—exercises that were deferred from Chapter 14 in order to make the latter principally a reading assignment.

Sections 15.3 and 15.4 introduce the Law of Inertia and are therefore critical with respect to all subsequent work.

Sections 15.5 and 15.6 deal with projectile motion largely for the purpose of introducing a simple, important, and easily understandable application of the Law of Inertia. The frame-of-reference overtones, however, are also important and fruitful. Under serious pressure of time, the work on projectile motion can be by-passed in favor of more important material that comes in subsequent chapters.

If Experiment 15.4 was performed earlier (as suggested in the Teachers' Handbook on Chapter 12), it need not be repeated at this stage, except for a review of its implications.

#### 15.2 Demonstrations

The Project Physics film loops referred to in Section 15.6 are excellent instructional devices and are very useful at this stage. If they are not available, however, other demonstrations or illustrations can serve the same purpose.

The end of this chapter is an excellent point at which to show the PSSC film "Frames of Reference." This film can still stake a claim to being one of the finest instructional films ever made.

The classic demonstration of the monkey and the bullet, available in one form or another in most lecture-demonstration collections, makes for a fun session and a good discussion at this juncture.

#### 15.3 Equipment

Experiment 15.1 is very easily set up with a burette as illustrated in Figure 15.1.1. An alternative source of water droplets might be a rubber tube syphon from any large container with the drop rate controlled

by a pinch clamp at the end of the tube.

Experiment 15.2: One meter stick per pair of students.

Activity 15.6, Project Physics Film Loops: Ball dropped from Mast of Ship (Damon Cat. No. 073910-1); Object dropped from Aircraft (Damon Cat. No. 073915-2); Projectile fired vertically (Damon Cat. No. 073920-9).

#### 15.4 Test and Examination Questions

Present your data and calculations for Experiment 15.1. Explain each step of reasoning in your calculations.

(Same question is applicable to Experiment 15.2.)

---

Suppose you obtained a flash photograph of a freely falling body.

(a) Sketch what you would expect such a photograph to look like.

(b) Outline in full detail how you would use such a photograph to calculate the numerical value of  $g$ , the acceleration due to gravity. (Start by indicating what specific data you would want regarding the photograph.)

---

Return to the situation analyzed in Problem 15.1.1. Suppose that another observer is located in an elevator (or balloon) rising vertically at a constant speed of +96 ft/sec. The stone is thrown upwards just as this observer comes by. Describe how the motion of the stone will appear to the observer in the elevator if this observer pays no attention to surroundings such as trees, ground, etc. but describes the motion of the stone only relative to the elevator—his "frame of reference." Is the observer in the elevator aware of any special behavior on the part of the stone when the observer on the ground claims it to be at the top of its flight? Explain your answer.

---

A baseball pitcher throws a ball vertically upward, and it leaves his hand with an upward velocity of about 80 ft/sec. An observer reports that the time of rise of the ball (the time interval between the instant it leaves the thrower's hand and the instant the velocity passed through zero and the ball started downward) was about 2.5 sec.

(a) Does the reported time interval make sense or is it obviously wrong? (Justify your answer by arithmetical reasoning accompanied by words of

explanation. Words alone will not do.) If the quoted time is incorrect give a two-figure value you conclude is closer to the truth.

(b) Suppose that a student, when asked to calculate the height to which the ball rises before starting back down, makes this calculation by multiplying 80 by the time interval you finally chose to be correct in part (a). Grade this work as correct or incorrect and write the student an appropriate note of comment, criticism, or explanation. (If any mistake has been made, the student should be made to understand the nature of his error.)

---

State the "Law of Inertia" in your own words. State the idealizations that are involved; i.e. how do we account for the fact that this "Law" does not seem to be obeyed in everyday phenomena?

---

Once a frictionless puck is in motion on a horizontal surface, what can be done to change the direction in which it is moving? Is it possible to change the direction of motion without changing the speed? What must you do to achieve such an effect?

---

Suppose a frictionless puck is in motion on a horizontal surface. Two equally strong pushes are applied to the puck in exactly opposite directions. Describe how the puck will behave under the combined influence of these two pushes.

---

Suppose that an object, known to be acted on by two or more external pushes or pulls, is observed to move in a straight line at uniform velocity. What conclusion can you draw about the applied pushes and pulls?

---

Make a sketch or tracing of Figure 15.5.1 in which the trajectories of two balls (one dropped vertically from rest and the other projected horizontally with initial velocity  $v_0$ ) are shown.

Suppose that a third, very much heavier, ball is added to the picture. It is also projected with an initial horizontal velocity, identical with the initial horizontal velocity  $v_0$  of the ball shown in the picture, and it is projected from the same starting point.

Add the images of the heavier ball to your sketch, explaining how you arrive at your conclusion as to what you expect to happen.

---

Suppose we give a ball on a table an initial velocity  $v_0$ . The following questions are concerned with what happens to the ball after it sails off the edge of the table.

(a) On the diagram below sketch the trajectory of the ball and label this trajectory (a).

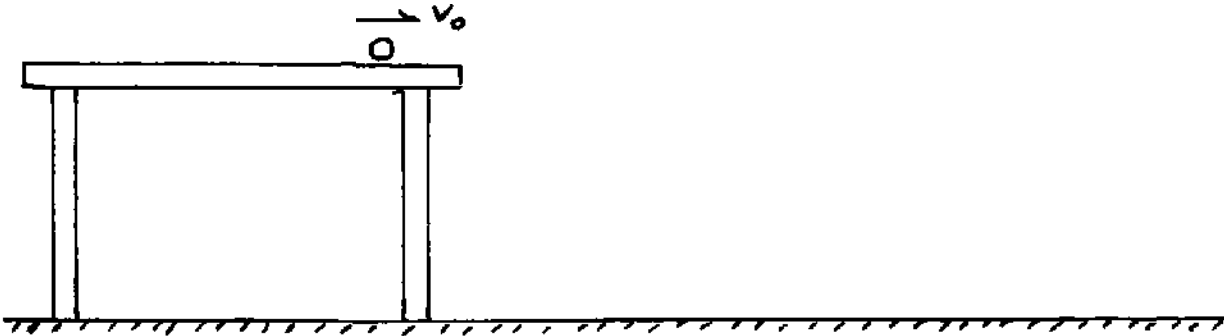

(b) Suppose we push the ball in such a way that it leaves the edge of the table with a higher velocity. Sketch the trajectory of this ball on the same diagram and label it (b). Defend your picture and explain your reasoning.

(c) Suppose we now use a heavier ball but push it in such a way that it leaves the edge of the table with the same velocity  $v_0$  as the ball in part (a). Sketch the trajectory of this ball on the same diagram and label it (c). Again defend your picture and explain your reasoning.

---

Suppose a ball is thrown or hit so that it follows a trajectory from A to E as that shown in the figure.

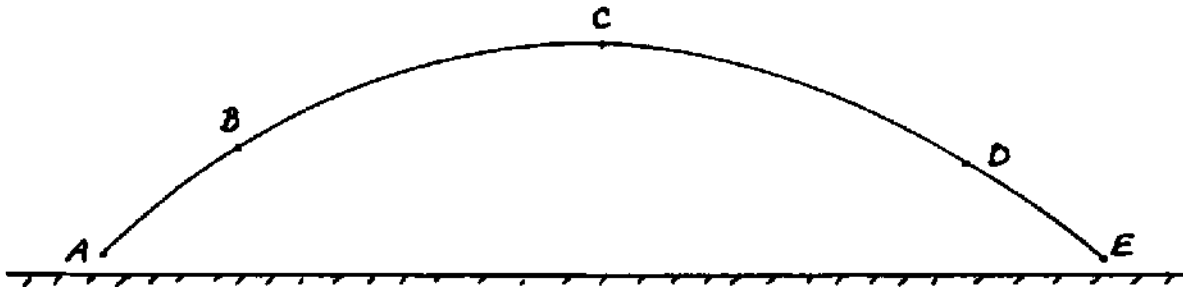

(a) If the effect of air friction is imperceptibly small what can you say about the horizontal motion throughout the trajectory? i.e. does the horizontal velocity remain the same? increase? decrease? Compare this specifically with some illustration or statement in your textbook.

(b) For this case (effects of air friction insignificant) show, by means of an arrow, the magnitude and direction of the instantaneous acceleration of the ball at each of the positions B, C, D in the above figure.



(c) If the effect of air friction is not negligible (as would be the case with a relatively light ball, for example), sketch the altered trajectory that might be expected and explain your reasoning.

---

## Chapter 16

### The Concept of Force

#### 16.1 Content

The function of this chapter is to introduce the force concept in a purely qualitative way via its connection to the Law of Inertia. Force is deliberately not quantified; the mass concept is not introduced explicitly; and vector aspects are kept minimal. The emphasis is entirely on interaction and the identification of the direction of effect on each interacting object. This means that Newton's Third Law is being introduced at the very beginning — with emphasis, however, not on the equality of the magnitudes of the two forces but on the fact that they are oppositely directed and act on different objects.

We have found this approach very effective with most students. It gives them a chance to develop a qualitative, intuitive sense for the meaning of "force" and the dynamics of many familiar situations before they confront the sophisticated overlay of quantitative aspects embedded in  $F = ma$ . For a great many students, deeper penetration than this is not actually necessary. For those who do go further, this introduction provides a far more effective springboard than the conventional quantitative sequence. As a matter of fact, we have come to feel that this introduction would be just as effective and desirable with science majors and engineers as it seems to be with non-scientists.

To make the study sequence effective, it is important that the students have access to the simple equipment with which they can observe and explore various interactions that are discussed in this chapter. Many of the situations invoked, however, involve simple, everyday items, and these situations can, of course, be observed and studied at home.

Students who can do correctly the various things outlined in the Learning Objectives are well on their way to a genuine understanding of the force concept. It is important to check what they have done — particularly the drawing of correct force diagrams and the giving of good verbal descriptions of the various forces — before allowing the students to go on to Chapter 17.

Chapter 17 continues the purely qualitative approach to dynamics, but it is designed to provide a degree of synthesis. The concepts of force and motion developed in the preceding chapters are applied to a number of familiar and deeply fundamental phenomena and to a resolution of questions raised earlier in the text about matters such as floating and sinking, the motion of atoms and molecules, and the motions in the solar system.

## 16.2 Film

The PSSC film "Inertia" is appropriate at this juncture while its sequel "Inertial Mass" provides a preview of further development.

## 16.3 Equipment

Carts with roller skate wheels and spring bumpers. Two per pair of student. (Carts such as those used in the PSSC and Project Physics courses, e.g. Damon Cat. No. 50022.)

Long flexible rubber bands, rubber balls, one per pair of students. Bricks for loading carts, two per pair of students.

Rod or bar magnets exhibiting sufficiently strong repulsion to allow non-contact collisions of carts moving at relatively low speeds, two per pair of carts. (Smaller, weaker magnets will serve the same purpose when taped to air-track gliders.)

Air track (1 meter) with assorted gliders, two per class of 30 students.

Spring balances (as in Figure 16.4.2, e.g. Damon Cat. No. 50009). Two per pair of students.

Incompletely closed hoop (as in Figure 16.7.1). Easily made by bending strip of brass or aluminum in conventional sheet bending machine.

PSSC centripetal force apparatus as illustrated in Figure 16.7.3. One per pair of students. (Alternative: Project Physics centripetal force apparatus as illustrated in Project Physics Handbook (2nd ed., 1975) p.39, Unit 1.)

## 16.4 Test and Examination Questions

The following questions pertain to a block of dry ice on a glass table top; frictional effects are to be considered negligible.

(a) On the diagram at right show all the forces acting on the block as it sits at rest on the glass plate. Give a brief verbal description of each force.



(b) On the diagram at right show the forces on the table due to the block. Do not include other forces on the table.

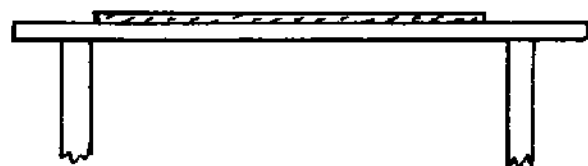

(c) If we give the block of dry ice a push, it sails along the table with a uniform velocity. On the diagram at right show all the forces acting on the block while it is moving at uniform velocity, that is, after the push. Give a brief verbal description of each force.



(d) Suppose we pull horizontally on the block of dry ice and keep pulling with the same force. Describe the motion of the block.



(e) Now suppose our two blocks are moving along the table together with a uniform velocity from left to right. Then we apply constant forces on the blocks as shown at right. Describe what happens to the motion of the blocks. Do they continue to move together? If not, how do you account for the difference?

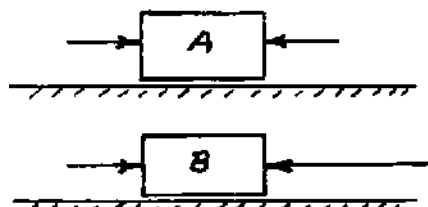



---

In the light of the Law of Inertia, which you should make use of in your explanation, give a qualitative operational definition of the term "force". (By qualitative definition, we mean one that identifies the concept in terms of actions and experience but does not attempt to assign a system of numerical measure.)

---

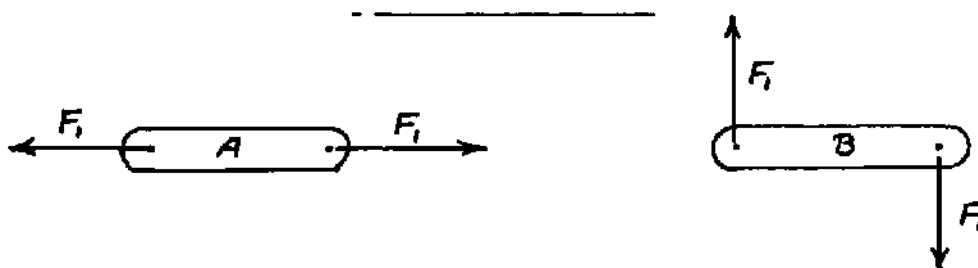
A cart, after having been given a push, is coasting along a horizontal floor and slowing down under the influence of friction. Draw separate and complete force diagrams of (1) the cart, and (2) the surface of the floor, showing the forces acting on each and describing each force in words.



Top View of Objects A and B on Frictionless Table

Two objects A and B are initially at rest on a frictionless table with no horizontal forces acting on them. Horizontal forces of constant magnitude  $F_1$  are simultaneously applied to each object as

shown in the diagram above and continue to act indefinitely. Describe how each object will behave after the forces are applied.

---

Consider a ball that has fallen vertically and collides with the floor in the process of bouncing. Draw separate force diagrams of the ball and the floor, describing each force in words. (Do not neglect gravity in this instance.)

---

(a) By analyzing what happens to the interaction between a book and the table surface on which it rests when (a) no external forces other than its own weight act on the book, (b) you press down on the book, (c) you gently tug the book upward without lifting it off the table, explain to a reader what is meant by a "passive" force. (Be sure to sketch all the relevant force diagrams and describe each force in words as part of your overall presentation. Also be sure to draw the book and table surface well separated so that the forces acting on each do not become confused on the diagram.)

(b) By re-drawing the diagrams, show the changes that take place in the situation described in part (a) when you proceed to press down on the book with your hand.

---

A plastic rod that has been rubbed with wool attracts bits of paper lying on the table when the rod is held well above the bits of paper. In fact the bits of paper frequently accelerate rapidly toward the rod.

(a) Sketch a force diagram of a bit of paper and of the plastic rod, giving a verbal description of each force shown.

(b) The interaction arising in these circumstances is called "electrostatic." In the light of what happens to the bits of paper, how would you compare the relative magnitudes of the gravitational and electrostatic interactions? Explain your answer.

---

We place a metal hoop down on the surface of a table, as shown in the top view diagram below.

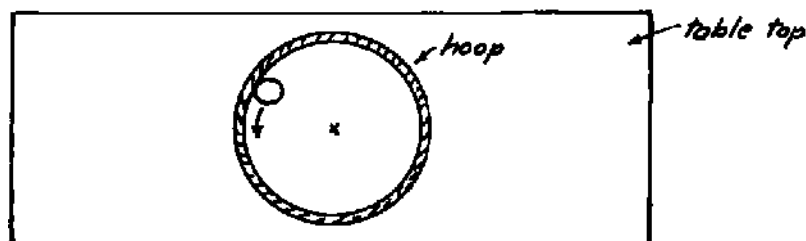

We start a ball rolling on the table inside the hoop. A side view diagram of the rolling ball at some instant of time is shown below.

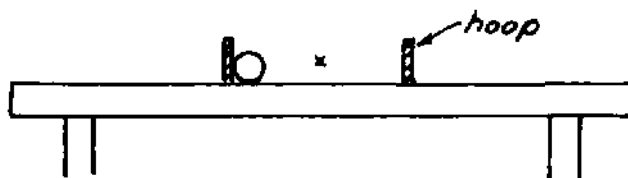

Draw a complete force diagram of the ball. Describe each force in words, i.e. what object exerts each particular force? Describe the role that each force plays in the motion of the ball, i.e. Does the force impart a net acceleration? Does it simply balance some other force? etc.

---

Consider the following statement that might be made by a beginning student:

"When an object moves in a circular path at uniform speed (covering the same number of meters of circular arc in each succeeding second), it is not accelerating and the net force acting on it must be zero."

How do you react to this statement? Is it correct or incorrect? If you regard it as correct, can you supply additional evidence and argument in support of the statement? If you regard it as incorrect, how would you correct it and how would you help the student to see what is wrong?

---

A box rests on the floor. Frictional effects are not negligible. You apply a horizontal pull to the box by means of a rubber band.

(a) For the case in which the pull you exert is not strong enough to accelerate the box: draw separate force diagrams of (1) the band, (2) the box, and (3) the surface of the floor, showing the forces acting and describing each one briefly in words. (When two forces are equal in magnitude, indicate this by making the lengths of the corresponding arrows equal.)

(b) Redraw the same diagrams for the case in which the horizontal pull is strong enough to accelerate the box. (When you know two forces to be unequal in magnitude, indicate this by showing the larger force with a longer arrow.)

---

You are sitting in a car which is moving at uniform velocity. The driver suddenly applies the brakes and the car slows down.

(a) Draw a force diagram of your own body for the situation that develops during the period of slowing down. (Be sure to make clear to the

reader the direction of motion of the system being examined.)

(b) A student at this stage of inquiry is very likely to say that you were "thrown forward" when the brakes were applied. Explain in your own words why this is an inappropriate and essentially incorrect description of what happens. Give what you would consider a better and more accurate description.

---

You are sitting in a car which is going around a curve at uniform speed.

(a) Draw a force diagram of your own body and describe each force in words. Compare this situation with that of the ball rolling inside a hoop and a frictionless puck held by a string on the air table (Experiment 16.7). (Such a comparison is made by pointing out similarities or differences in the respective force diagrams.)

(b) A learner at this stage of inquiry is very likely to say that your body is being "thrown outward" as the car goes around the curve. Explain in your own words why this is an inappropriate and essentially incorrect description of what is happening. Give what you would consider a better and more accurate description.

## Chapter 17

### Dynamics: Applications of the Force Concept

#### 17.1 Content

As indicated previously, this chapter continues the purely qualitative development of the dynamical concepts introduced in Chapter 16, but the focus is now on achieving some degree of synthesis. The concepts are first applied to directly accessible phenomena on the laboratory scale and are then extended to encompass the solar system on one hand and the microscopic world of atoms and molecules on the other. At the same time, there is an explicit circling back to the big questions originally raised in Chapter 1 as well as a re-emphasis of the intellectual significance of comprehending how we know and why we believe various scientific concepts and theories — in contrast to accepting them as end results received from authority.

Finally, there is an attempt, at a preliminary and unsophisticated level, to discuss the deep philosophical question of what we mean by understanding and explanation in science. Some exposure to this question is a particularly important component of the general education aspect of any science course. The more a student has been afraid of science and the more insecure he feels about his ability to grasp and comprehend it, the more he tends to endow science with capacity for attaining absolute truth, final answers to all questions, and knowledge not subject to change. It is the purpose of Sections 17.8 and 17.9 to form a more realistic perspective and to give the student a feeling that he has the intellect with which to assess both the power and the limitations of the insights he is acquiring.

Two sections of this chapter are particularly worthy of class discussion for at least one hour each:

A. Section 17.6 on the two-body system. In this section the student is being invited to re-discover Newton's great insight — that the same interaction that makes the apple fall might possibly bind the moon to the earth and the earth to the sun. Here is embodied one of the most dramatic aspects of the concept of uniformitarianism: that there is nothing special about the earth, and that the regularities we observe in the terrestrial domain may apply to the celestial one as well. These ideas will be discussed more explicitly in Chapter 18, but the students will acquire a far deeper grasp of their significance, and of the revolution they caused in human thought, if they begin to articulate them, however naively, out of their own experiences in this chapter.

A particularly important overtone resides in the application of the Third Law to the gravitational interaction: if the earth exerts a gravitational force on an object, we expect, in the light of all the other interactions we have observed directly, that the object exerts an



equal and opposite force on the earth. It is through this uniformitarian line of inductive reasoning that we arrive at the conception that the earth and moon might form a two-body system with revolution around a point closer to the more massive member of the pair.

B. Section 17.7 on the kinetic theory of matter. Here the students should be drawn into discussion of the inductive reasoning entering into construction of the model. What motivates the visualization of extremely small particles with spacing comparable to molecular size in liquids and solids and vastly larger spacing in gases? What motivates the visualization of perpetual molecular motion? What motivates the visualization of perfectly elastic collisions?

A kinetic theory demonstration apparatus plays a vital role in the discussion related to building up the model. Students should be allowed to observe the gas condition and to list carefully and completely all the things they see happening and all the characteristics they can describe (collisions, varying spacing, varying distances between collisions, distribution of velocity, instantaneous condition of the population, behavior of one molecule over a long time, diffusion, bombardment of walls, etc.).

Finally they should be led to discuss several of the descriptive applications of the kinetic model as in Section 17.8 D.

## 17.2 Demonstrations

It is very desirable to perform the following demonstrations:

A. Exhibit (and let students play with) a Cartesian Diver in connection with Section 17.2. The best system is to make the diver out of a short piece of glass tubing open at one end and sealed at the other. Students can then adjust the amounts of air and water in the tube until it exhibits the classical behavior.

B. Kinetic theory demonstration in connection with Section 17.8. There are numerous kinetic theory demonstrators available from the apparatus supply houses, and virtually all of them are adequate for the present qualitative discussion. To make it an effective part of class discussion, we have found the most satisfactory demonstrators to be those that can be manipulated on an overhead projector.

C. In connection with Section 17.8, it is desirable to exhibit some large, well-formed crystals of different substances. It is also particularly useful to have several different sized crystals of one substance in order to show the rigorous maintainance of shape and angles. Models in the form of systems of close-packed spheres are also useful.

### 17.3 Equipment

Experiment 17.2 C. Floating and Sinking: Buckets or large cans to contain water. Pieces of wood, stone, metal for immersion.

Experiment 17.6. Revolution of two-body system: Air table with pucks (See Figure 17.6.1). The experiment can also be performed, at the cost of somewhat greater friction, on a table surface covered with small plastic beads (e.g. Plastic Dylite Beads, Damon Cat. No. 50024).

Experiment 17.7. Several different kinds of crystals with characteristic terminations (quartz, tourmaline, etc.). Also sugar, salt, etc. that can be examined with a magnifying glass. Beads or ball bearings that can be close packed to simulate a two-dimensional crystal structure.

### 17.4 Test and Examination Questions

"Archimedes' Principle" is the name for the statement that an object immersed in a fluid is acted on by a force equal to the weight of the fluid displaced.

Using appropriate force diagrams, present an argument that justifies this statement. In the process, show that the force being referred to must be directed upward and must be exerted on the object by the surrounding fluid. Also, with appropriate force diagrams and with careful reference to the meaning of "density", show what will happen (rising or sinking) to submerged objects whose density differs from that of the surrounding fluid.

---

You are holding a piece of wood in one hand and a stone in the other completely submerged in a pan of water. Draw force diagrams of both the wood and the stone, showing the forces acting on each object. Describe each force in words. Indicate relative magnitude of each force by the length of the arrow. Be particularly careful with respect to including the effect due to your hand.

---

Drawing separate, complete, and careful force diagrams (one for your own body, the other for the surface of the ground or floor), explain how it is possible for us to walk or run, i.e. to accelerate our bodies to some non-zero velocity starting from rest. Give a very specific and precise identification and verbal description of that force which imparts the acceleration in which we are interested.

---

Suppose we take a toy balloon and blow it up with air. If we then let the balloon go without tying up its mouth to prevent the air from

rushing out, it is a familiar experience that the balloon deflates, and, as it does so, flies erratically around the room.

Explain the behavior (i.e. acceleration) of the balloon in terms of the concept of "force" that we have just started developing. (Note that we have previously shown gases to be material objects; they have measurable mass and are capable of exerting forces on other material objects.)

Be sure to include appropriate force diagrams of the balloon and ejected parcels of air as part of your explanation.

---

(a) Sketching force diagrams of a propeller and the parcels of water it drives backwards, explain how a propeller propels a boat.

(b) Explain why a rocket engine rather than a propeller must be used on a space vehicle.

---

Suppose that you are standing in an elevator which is moving in the downward direction and is slowing to a stop. Draw a force diagram of yourself, using the length of force arrows to indicate relative sizes of forces (i.e. a larger force should be represented by a clearly larger arrow; equal forces should be represented by arrows of equal length). Describe in words the origin of each force you draw and explain your reasoning concerning their relative sizes.

---

Suppose you are standing on a bathroom scale in an elevator which is accelerating downward.

(a) Draw separate diagrams of your body and the bathroom scale. Show the forces acting on each object and label each force with a brief verbal description referring to what is acting on what.

(b) How does the reading on the bathroom scale during the period of uniform downward acceleration compare with the reading when the elevator is standing still? Explain your reasoning clearly and carefully.

---

This question concerns a simple action — the dropping of a ball — which is observed in three different frames of reference: on the ground, inside an elevator, inside a satellite. You are asked to describe and compare what is seen under different conditions from different points of view.

(a) A ball is released from rest relative to the inside of an elevator with transparent walls under the following different circumstances:

- (1) the elevator is at rest
- (2) the elevator is moving upward at uniform velocity
- (3) the elevator is falling freely (i.e. the elevator cable breaks).

Using both words and sketches, compare the trajectories of the ball as observed inside the elevator and by an outside observer remaining on the ground.

(b) A ball released inside a transparent satellite in orbit around the earth.

Using both words and sketches, compare the trajectory of the ball as observed inside the satellite and by an observer on the earth (gifted with extraordinary vision).

---

If we leave a beaker of water uncovered in a room or out of doors, the liquid water gradually disappears. The water, of course, does not vanish. It is found in the form of water vapor dispersed through the air. The process of transformation from liquid to vapor is called "evaporation".

(a) In the case of the uncovered beaker, all of the liquid eventually disappears. If, however, we cover the beaker, leaving an air space over the liquid as shown in the figure, it is an observed fact that only a tiny amount of liquid evaporates, after which the liquid stops disappearing. The system then remains unchanged as long as the beaker remains covered. In terms of the atomic-molecular model, describe what you visualize to be happening on the microscopic scale in the case of the open and in the case of the covered beaker. Use sketches to illustrate your thoughts.

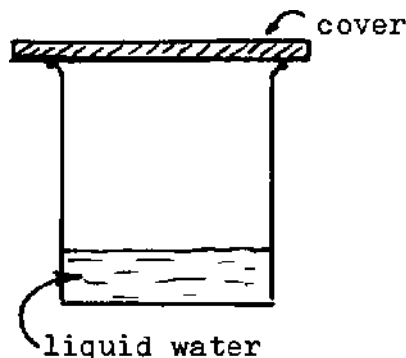

(b) Suppose we increase the temperature of the water in the beaker. Would you expect to observe any changes in the processes taking place in the systems of part (a)? Explain your reasoning, and, if you expect some observable changes, indicate what it is that you expect.

---

A substantial quantity of salt (solid) is placed in a beaker of water, and the system is stirred. It is observed that some of the solid

disappears, dissolving in the water. After a while, the dissolving ceases, the system attaining the condition we have previously defined as that of a "saturated solution."

In terms of the concepts and models developed in Section 17.7, describe what happens in this system on the microscopic (atomic-molecular) level. Start at the very beginning when the salt is added to the water, and there is not yet any salt in solution. Follow the process right through to the condition of saturation. Give a clear description of how you visualize what is going on when equilibrium is reached, i.e. have all molecular processes and activity ceased at equilibrium or is there still something going on? (Do not confine yourself to words alone; illustrate your description with pictures or diagrams.)

---

Suppose that a large chunk of solid sugar is placed in a beaker of water. We observe the following phenomena:

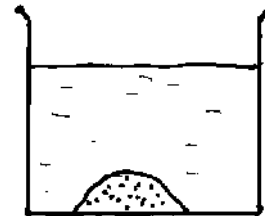

(11) Some of the sugar disappears and we find it uniformly distributed through the water. We get the sugar back upon the evaporation of the water. We speak of this as "dissolving" or "forming a solution" of sugar in water.

(22) At any fixed temperature sugar has a definite "solubility" in water. The dissolving process stops and a chunk of sugar remains at the bottom off the beaker in contact with the solution.

(aa) How would you describe this process of dissolving (forming a solution) of solid sugar in liquid water in terms of the atomic-molecular model?

(bb) How does this model account for the existence of a definite solubility at a fixed temperature? Why does the dissolving process cease with a chunk of sugar remaining undissolved at the bottom of the beaker? (Describe how you visualize the condition of "saturation" in atomic-molecular terms: what is happening at the sugar-water interface? has the motion of the molecules ceased or is there a process still going on? what is happening while the solution concentration is below the saturation value?)

---

It is an observed fact that the pressure of a gas increases as the temperature increases while volume is held constant. In terms of the corpuscular model, how might we account for the pressure increase? What connection is suggested between temperature and the motion of the molecules? Explain your reasoning in detail.

---

## Chapter 18

### The System of the World

The emphasis in this chapter is deliberately concentrated on historical narrative together with the impact of this branch of scientific thought on our present outlook toward ourselves and our place in the universe. The substantive scientific content is understated accordingly, although a certain amount of qualitative material is introduced to maintain plausibility and continuity in the logical structure. We have used this material principally as collateral reading during the second quarter of our course and have not accorded it a significant amount of class time.

If it is desired to pursue this area of subject matter somewhat more intensively within class time, we would recommend that it be coupled with the excellent presentation and laboratory materials associated with Part 2 of the Project Physics Course.

Spot-checking performance on the learning objectives stated in the Study Guide is a useful way of establishing whether the chapter has been thoughtfully read and understood. Checking the students' grasp of the broader content of this chapter—its overall point as the story of a major sequence of development in our own intellectual history—is highly desirable but can probably only be achieved through extensive discussion or the writing of essays or term papers.

## Chapter 19

### Forecasting Motion

#### 19.1 Content

The purpose of this chapter is to provide operational definitions of force and mass together with an introduction to Newton's Second Law, concentrating on application of this quantification to physical situations such as those discussed qualitatively in Chapters 16 and 17. If time requires, this chapter can be omitted without doing violence to the material in subsequent chapters.

The analytical level is deliberately subdued. We see little to be gained from lengthy exercises on vector arithmetic and composition of forces. On the other hand, there is a very important conceptual element behind the notion that a force does have an effect in directions not parallel to its own and that this effect is reduced in magnitude with increasing obliquity, becoming zero in the orthogonal direction. Experiment 19.6 is introduced in order to establish this insight.

Jargon with respect to "components" and with respect to trigonometric functions is deliberately avoided. The instructor can always introduce these ideas to students who raise the appropriate questions and give signs of being ready for the extended terminology. For those students who are ready, this is an excellent point at which to introduce the concepts of sines, cosines, and tangents as intrinsic properties of angles. The motivation is clearly established by the experience generated in Experiment 19.6.

The expression  $v^2/R$  for centripetal acceleration is asserted, and the derivation is relegated to Appendix E. Those students who are ready for such an analysis can be directed to the Appendix. For other students, it is quite adequate to lead them into perceiving that  $v^2/R$  makes sense in terms of their qualitative observations and experiments in Section 16.7, particularly Experiment 16.7 E.

A very profitable group discussion can be held on the distinction between gravitational and inertial mass. (This subject is not discussed in the text.) The following approach is recommended:

A. Describe or demonstrate the Cavendish experiment in which it is shown that an object ("Body B") brought near one of the spheres ("Body A") constituting the torsion balance attracts this sphere, causing Body A to accelerate and the balance to swing (an excellent demonstration of this effect is made with bottles of water and boxes of sand in the PSSC film "Forces").

B. Suppose we select a "Body C" that, in the acceleration experiments described in Section 19.3, exhibits exactly one half the acceleration of Body B under the influence of the same net force, i.e. Body C has twice the inertial mass of Body B.

C. We then imagine comparing the pulls exerted by Bodies B and C on the reference body (Body A) on the torsion balance. It is an observed fact that Body C exerts exactly twice as large an attractive force on Body A as does Body B. It should be emphasized that this need not have been the case. We are dealing with two entirely different properties: inertial mass has to do with the resistance of the body to being accelerated by an external force, while the Cavendish apparatus reveals the pull this body exerts on another object. In fact, when the interaction among Bodies A, B, and C is that which develops after they have been rubbed with plastic or cloth (i.e. when they are electrically charged), the strength of interaction bears no relation whatsoever to their inertial masses. The fact that the gravitational effect of Bodies B and C on a third body (Body A) is always in the same ratio as the inertial masses of B and C represents a remarkable restriction. Nature must be trying to tell us something. It is useful to emphasize that we might have described the capacity to attract a third body as "gravitational charge" rather than "gravitational mass." We are the ones who confuse the issue when we adopt the same name for two entirely different properties.

All of the above can be usefully brought out in an interesting and not too lengthy group discussion. Very few students are aware that "universal gravitation" is indeed universal and that all objects, including our own bodies, attract every other object. They have never seen the effect and they have not set it in the perspective that the exceedingly small gravitational force is obscured by the vastly larger forces present in most of the terrestrial interactions we observe in everyday experience.

Laboratory work is not necessary in connection with Sections 19.1 - 19.5, but, while students are concerned with the thought experiments invoked in these sections, the time is very opportune for showing the PSSC films on "Inertia" and "Inertial Mass." These two films, although they do not directly illustrate the operational definitions of force and mass as we develop them in this chapter, are nevertheless closely related to the thought experiments that are invoked and do give direct illustration of the superposition of forces and masses.

The learning objectives stated in Section II of the Study Guide do not include insights that are added in some of the more lengthy and extended investigations of Question and Problem Section 19.8. If substantial time is devoted to assignments out of this section, the Learning Objectives should be expanded accordingly.

## 19.2 Equipment

Equipment needed for this chapter is directly illustrated in Figures 19.6.1, 19.6.2, and 19.6.5: PSSC or Project Physics carts, string, pulleys, weight pans, weights, spring balances, planks to be used as inclined planes.

For Problem 19.8.3: loop-the-loop apparatus of the type illustrated in Figure 19.8.2.



### 19.3 Test and Examination Questions

Suppose two objects, A and B, are released simultaneously and allowed to fall freely. The mass of object A is larger than the mass of object B. The effect of resistance is negligible.

(a) How do the accelerations of objects A and B compare? i.e., indicate which object has the larger acceleration, or whether both accelerations are the same.

(b) How does the net force on object A compare to the net force on object B? Explain your reasoning.

---

(a) If you use a lawn or tennis court roller, you can propel it either by pushing on the handle as indicated in (a) or by pulling as indicated in (b). If you are very short, you might even pull it as indicated in (c). Let us suppose that in each case the roller moves along at uniform velocity.

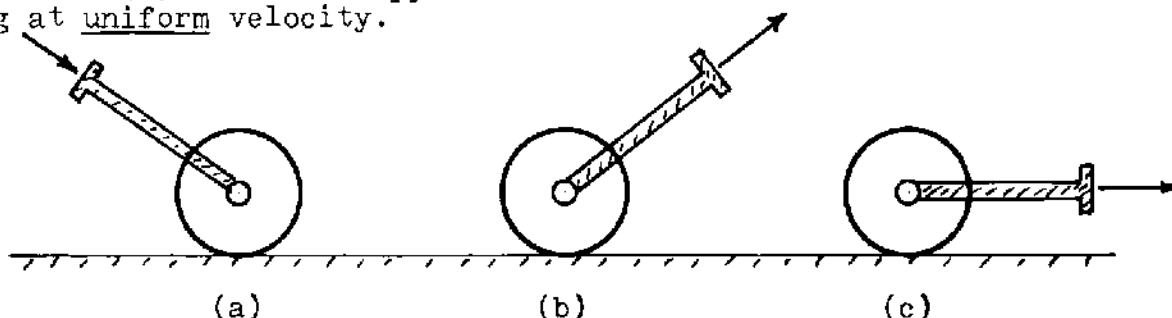

For each of the three cases above draw two separate force diagrams: one diagram showing all the forces acting on the roller and a separate diagram showing the forces acting on the ground. Label each force with a verbal description of what object exerts the force on what.

(b) The point of doing such rolling is, of course, to get the ground as smooth as possible. How do the above three ways of propelling the roller compare with each other in this respect? Will all three ways do equally well? Would one do a better job than the others? Give a clear and complete explanation of how you arrive at your conclusion. (You can help your argument enormously by referring to other situations that you have now thought about but which you may not have conceived as having any connection with this one.)

---

The figure below shows a pendulum bob suspended on a string and pulled aside from its vertical rest position. When the bob is let go, it proceeds to swing back and forth in familiar fashion.

Suppose that a flash picture is taken of one swing from left to right and that the flashes come frequently enough to catch the bob at about nine positions altogether, including the starting position shown in the

figure. Complete the figure, showing what you expect the flash photo to look like. Make your sketch slowly and carefully, not hastily and sloppily. In the space at the right, give a brief explanation of why you have drawn the figure as you have, i.e. why do you expect the particular pattern of speeding up or slowing down or uniform motion that you may have shown.

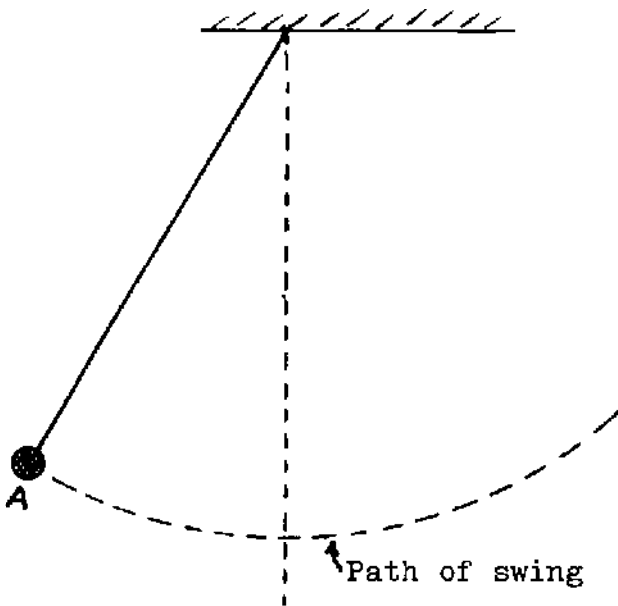

Now draw the following three force diagrams of the bob: (a) a diagram showing the forces acting on it immediately after it is let go from the initial position A in the figure above; (b) a diagram showing the forces acting on the bob just as it passes through the lowest point of its swing; (c) a diagram showing the forces acting on the bob at the instant it reaches the end of its swing on the right hand side. Label the diagrams clearly and identify the forces shown on each diagram. Are your force diagrams consistent with the flash picture you have sketched? Explain clearly and carefully as though you were talking to a student not already quite familiar with the ideas involved.

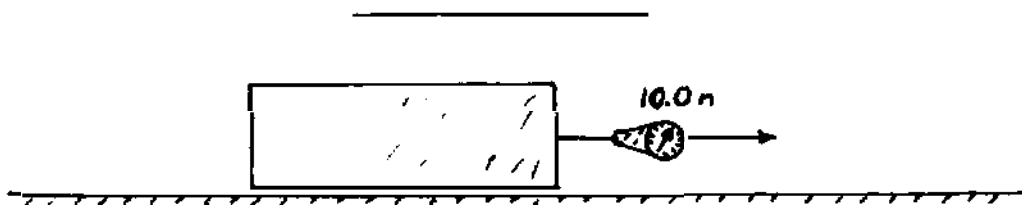

A light cloth covers an object which is being pulled to the right along a frictionless surface by a spring as shown in the diagram above. The object has a mass of 5.0 kg. A constant force of 10.0 newtons is recorded on the spring scale. The mass of the cloth and of the spring are negligible compared to the 5.0 kg.

(a) What is the acceleration of the system?

The cloth is removed revealing that the object actually consists of two

parts as shown in the diagram below. There are two masses (2.0 kg and 3.0 kg) connected by a second spring scale.

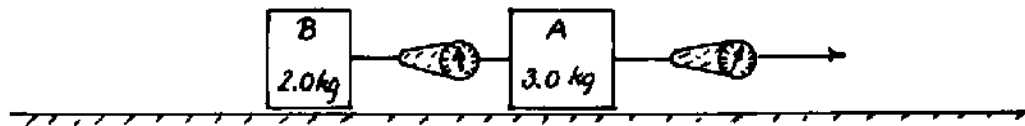

(b) What force does the second spring scale indicate? Explain your reasoning. (Hint: what must be the net force acting on body A in order to impart the acceleration calculated in (a)?)

---

## Chapter 20

### Another Kind of Motion: Waves

#### 20.1 Content

This chapter leans heavily on the approach and the equipment used in the excellent introduction to wave phenomena in PSSC Physics. Its concreteness and accessibility provide a welcome change of pace from the more abstract concept building of the previous chapters. Students enter into the experiments with verve and enthusiasm.

The most subtle content is in Experiment 20.6 in which analysis of reflected wave shapes is based on satisfying the boundary condition at fixed and free ends. Many students need interaction with an instructor on this particular material, as well as on the exercises dealing with superposition of wave shapes in Experiment 20.5. Few students have difficulty with any of the other sections.

We have not found it necessary to have group discussions on this subject matter. It sustains itself quite effectively.

#### 20.2 Equipment

The best equipment for the one-dimensional wave experiments consists of the long "slinkies" and other coil springs specified for the waves chapters of the PSSC Physics Course and now carried by most of the principal apparatus supply houses.

The slinkies and coil springs are fruitfully supplemented (or, if necessary, substituted) by different diameters of rubber "shock cord" available in many hardware or marine supply stores and by laboratory rubber tubing. The "impedance" of the latter can be increased, if desired, by filling thin-walled tubing loosely with sand.

#### 20.3 Test and Examination Questions

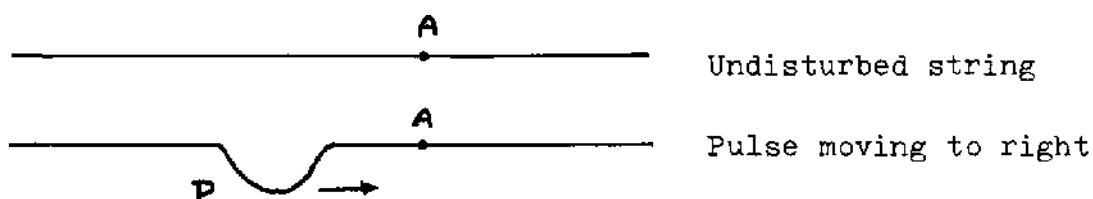

Describe in detail the motion of point A of the string as the pulse P goes by. Do not include the motion of point A due to the reflected

pulse. (When is particle A moving upward? downward? when does it have zero instantaneous velocity? etc.)

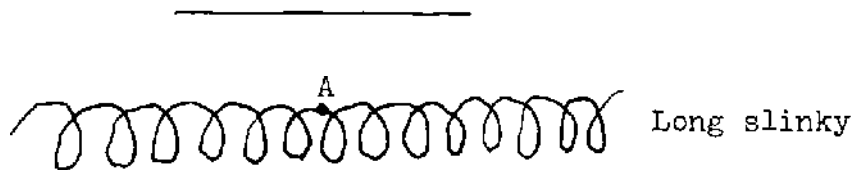

A rarefaction wave pulse propagates from right to left ( ←————— ). Do the individual coils of the spring move as the wave passes?

If they do move, in what direction will point A be displaced during passage of the rarefaction phase?

\_\_\_\_\_

Suppose we have a wave pulse in a spring travelling to the right with the shape shown in the diagram below.

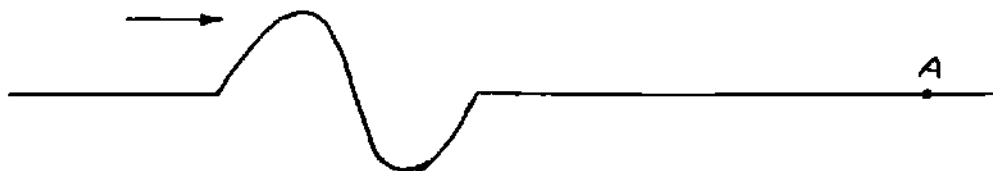

(a) On the diagram above sketch the pulse as it would appear a very short interval of time later. Show the direction of motion of the particles in the spring in a manner analogous to Figure 20.3.3.

(b) Draw a graph of transverse deflection  $y$  versus clock reading  $t$  for the particle at position A, starting at the instant of time shown in the diagram above.

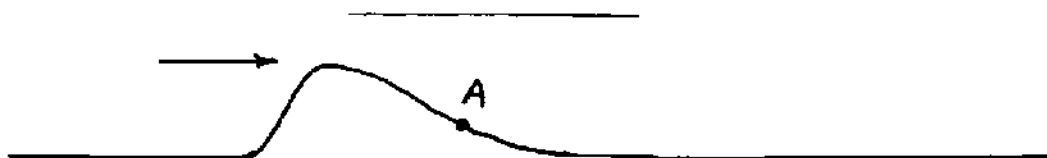

(a) The transverse wave pulse shown above propagates to the right along a rope. On a diagram below show the shape of the wave pulse propagating to the left along the same rope that could for an instant cancel this one completely.

(b) On a diagram below show the location and shape of a pulse that could

keep point A undeflected as the pulses passed through each other.

Pictured below are two idealized transverse wave pulses A and B on a rope (1) at the instant  $t_1$  just before they begin to overlap; (2) at the instant  $t_2$  just after they have passed through each other.

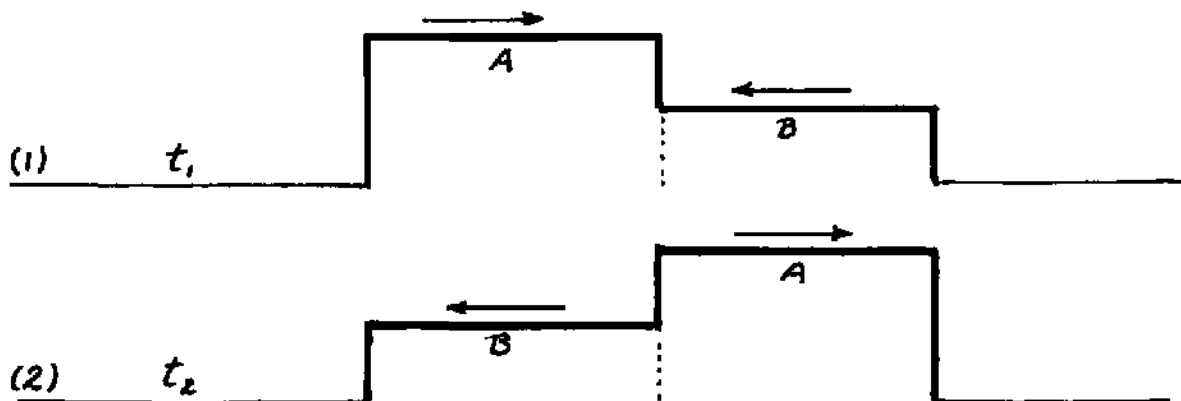

On diagrams below, plot the shape of the rope at three successive, equally spaced stages of superposition between instants  $t_1$  and  $t_2$ .

Illustrated below are two idealized transverse pulses on a single spring at  $t = 0$ . Each pulse travels with a uniform velocity of 1 square /sec. in the directions indicated. Answer the following questions concerning these pulses:

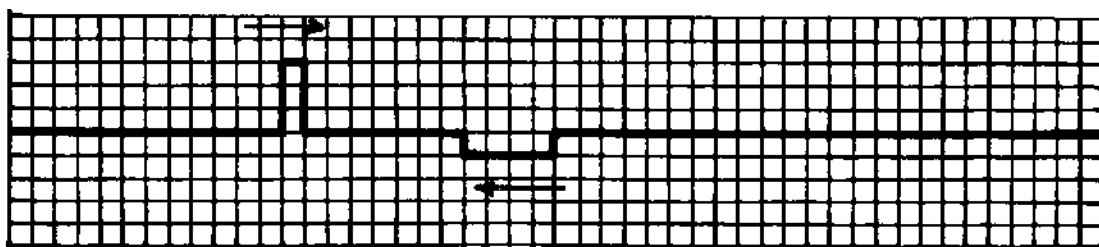

Describe in your own words what happens, in general, when two pulses pass through each other.

Sketch the appearance of the spring at  $t = 5$  seconds.

Sketch the appearance at  $t = 7$  seconds.



Suppose we have a long cylinder full of air as shown in the diagram. It is closed by a piston that we can slide back and forth at one end.

Suppose we abruptly move the piston a small distance to the right and generate a single pulse. Sketch a sequence of three or four pictures of the air in the tube as the pulse moves along it. What connection do you see between this situation and longitudinal pulses on the slinky?

Identify an appropriate property for the y axis and plot a graph of this property as it varies with position along the tube at a particular instant.

---

## Chapter 21

### Waves in two Dimensions

#### 21.1 Content

This chapter continues the process of shifting responsibility to the student for his own learning. It consists mostly of study guide and leading questions with very little expository text. We find that the majority of students have achieved this level of responsibility by this point in the course, but there are some who still lag behind and do not synthesize the observations and inferences associated with the experiments. The latter require some interaction with instructional staff while engaged in the ripple tank observations. It is most important that this interaction take the form of socratic questions rather than directions as to what to do and what to conclude. Many of these students are on the verge of breaking through to a new plateau of independent study and learning. They should not be cheated of this opportunity.

The ripple tank is one of the most effective pieces of laboratory apparatus in our arsenal. Students enjoy working with it and value the learning experience. It is highly desirable to have enough equipment for students to be able to work in pairs, although having four at a ripple tank is, if necessary, an acceptable compromise. With more than four students per set-up, most of them become spectators, and the educational returns diminish rapidly.

The tanks should be equipped with the conventional accessories such as barriers of various shapes and sizes, hand stroboscope, wave generators, etc. We advise that the motor-driven wave generators be kept under wraps until the students have performed Experiments 21.1 - 21.3 with pulses. Otherwise they plunge immediately into experiments with continuous wave trains and fail to discriminate between phenomena that are common to both pulses and wave trains on the one hand and phenomena unique to continuous wave trains on the other.

The following aspects are deliberately underplayed or entirely omitted from investigation at this stage:

- (a) Critical angle for total reflection,
- (b) Huygens' Principle,
- (c) Derivation of the Law of Reflection and Snell's Law from the requirements imposed by propagation velocities.

Any or all of these items can be introduced as additional optional or required units at the discretion of the instructor. They can be particularly valuable to those students who are well ahead of the majority. Among our own students, however, we have been satisfied with the trade-off in which we have sacrificed quantitative penetration for more independent study. To the future elementary school teacher, a secure qualitative understanding of these phenomena is far more valuable



than an evanescent treatment of Snell's Law, which will never see any important use or application in their own teaching.

There are many excellent film loops available on virtually all aspects of ripple tank phenomena, including Doppler effects, etc. Having these loops available for student viewing is exceedingly worthwhile — even when there is no intention of incorporating all the exhibited phenomena within the required spectrum of the course itself.

Instructors will note that diffraction and interference are not being investigated at this juncture. We find that proceeding immediately to these phenomena gives the students too big a volume of new material at too fast a pace. We will first re-apply the concepts of reflection and refraction in examination of the behavior of light and subsequently spiral back to diffraction and interference both in the ripple tank and in optics.

## 21.2 Equipment

Ripple tanks with standard accessories are now available from most of the principal supply houses. The basic items needed are: tanks, lamps, various barriers, rods or dowels, roll of white butcher paper for screen, wave-train generators and batteries, glass plates to produce shallower regions for refraction, hand stroboscopes.

## 21.3 Test and Examination Questions

The following diagram shows a wave front incident at an interface separating regions of different propagation velocity.

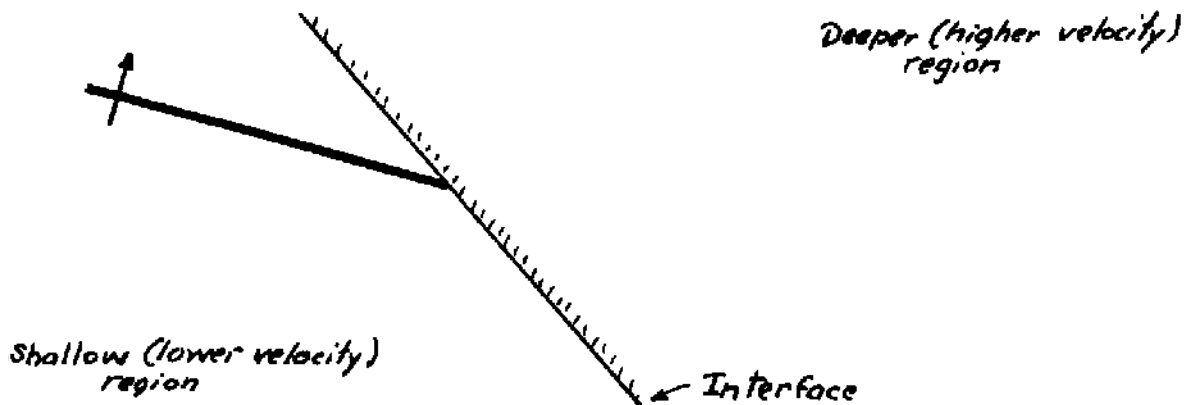

(a) Draw and label the reflected and transmitted wave fronts.

(b) Draw the normal to the interface at point  $O$ . Draw the incident, reflected, and transmitted rays that intersect at point  $O$ . Label each ray (incident, reflected, transmitted) and also mark and label the angles of incidence, reflection, and refraction.

Suppose we generate water wave pulses in the ripple tank and look at their reflections from rigid barriers.

On the diagrams (a) and (b) below, draw the reflected wave fronts that go with the particular incident wave fronts shown. Indicate with arrows the direction of propagation of the reflected wave fronts.

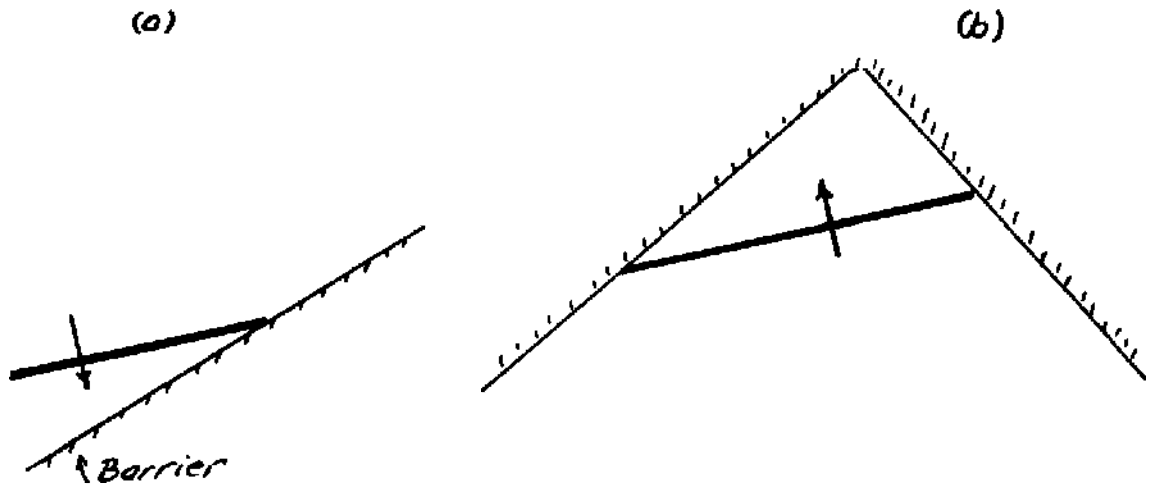

In the diagram below are shown two successive incident wave fronts arriving at a lower to higher propagation velocity interface. The direction of propagation of the incident waves is indicated by the arrow.

Add to the diagram lines that show the location, at this instant of time, of the reflected and transmitted wave fronts that go with the two incident wave fronts shown. By means of arrows, indicate the direction of propagation of the wave fronts you have drawn.

In the space at the right, redraw this same situation showing only the corresponding rays instead of the wave fronts. Label each ray with a short phrase describing what it represents.

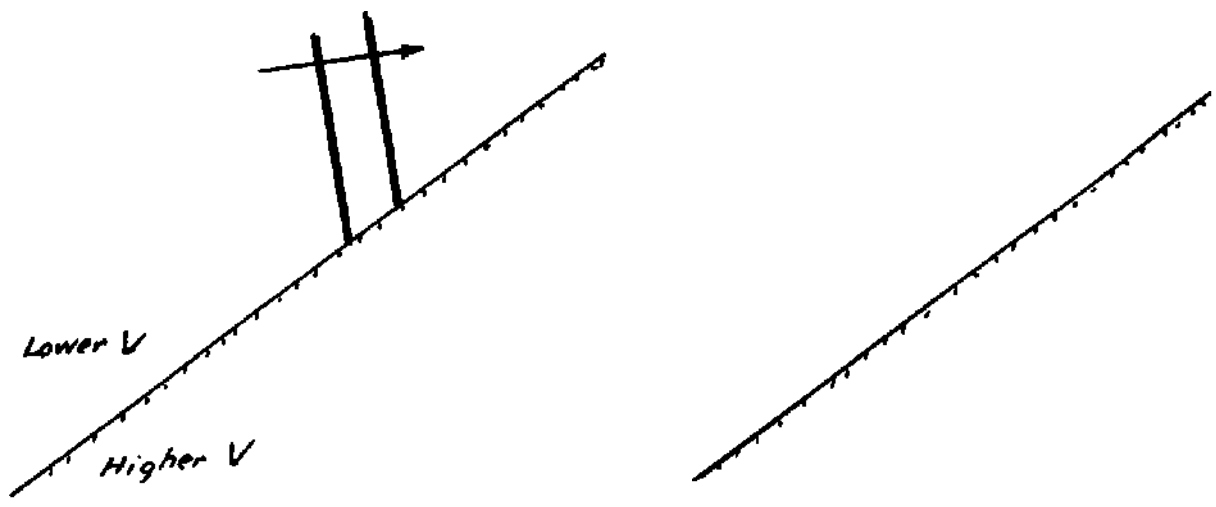

Describe what is observed to happen to the wavelength of a continuous wave train when it crosses an interface between regions of deeper and shallower water.

Explain how this observation leads to the conclusion that the propagation velocity of the wave must be lower in the shallower water.

Suppose that we have a water tank which is filled exactly to the brim as shown in the figure, and we proceed to make single pulses on the water surface.

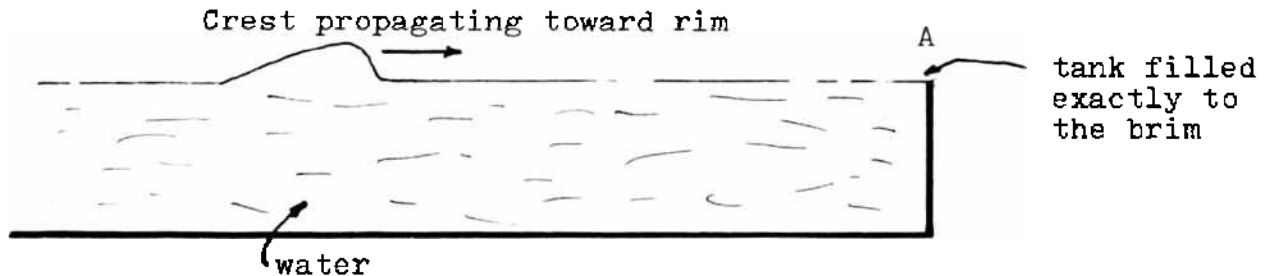

A crest, propagating on the surface as shown, arrives at the brim at A, and a reflection occurs at the brim since this is clearly a case of an abrupt change in the medium of propagation. (The events at the brim will include a slight amount of spillage of water over the side of the tank, but let us not worry about this aspect in any detail.)

The question to be addressed is: what will be the nature of the reflection from the brim? will it be a crest or a trough? Explain your line of reasoning and sketch an idealized version of the reflected pulse. (Note that the level of water at the brim cannot change appreciably — as it can in sloshing up along a higher barrier.)

## Chapter 22

### Reflection and Refraction of Light

#### 22.1 Content

Apart from beginning to construct the wave model for the behavior of light, this chapter also cuts across substantial areas of subject matter found in the elementary science curricula: formation of shadows, reflection from plane mirrors, refraction effects, color. The material is not handled in the same way or investigated as extensively as in some units of the elementary curricula, but an understanding of the content of this chapter provides the future teacher with a base from which he or she can more readily approach and master the specific units on light and optics that might be encountered in subsequent teaching.

It is particularly effective to have students make short segments of motion pictures, filming optical phenomena they notice out-of-doors. These films can then be presented to the class and discussed. Such activity is enjoyed by the students and greatly enhances their capacity to notice and observe phenomena taking place outside the laboratory.

Throughout this chapter, we have tried to be flexible and relatively non-committal with respect to the kind of equipment to be utilized in the experiments. Many different types of equipment serving essentially the same ends are available in physics laboratory stockrooms, and there is no reason why any specific make or type need be locked in with this particular chapter.

The optics equipment associated with the PSSC or the Project Physics courses is fully adequate for the present needs. Optics kits (such as Sargent-Welch ray box, cat. no. 3665A) can be exceedingly useful. An instructor can readily improvise much of what is needed out of stock items obtainable from the scientific supply houses or from an optics specialist such as the Edmund Scientific Co.

Under severe pressure of time, it is possible to demonstrate the basic facts about reflection and refraction of rays of light with an apparatus such as the Hartl Optical Disk or the various wall-mounted demonstrations that are frequently available in lecture demonstration stocks. Such demonstrations, however, are never as effective as allowing the students to thrash it all out for themselves. If recourse is made to demonstration, it should be done very slowly, in the course of class discussion, with the students describing what is observed and making sketches of each experiment.

Also under pressure of time, Experiment 22.4 on image formation in plane mirrors can be by-passed without interrupting the main sequence of inquiry leading to the validation of the wave model.

On the other hand, if it is desired to devote more time to geometric optics, this is a point at which it could be fruitful to digress

into areas such as

- (1) Image formation by curved mirrors,
- (2) Snell's Law, using an apparatus such as the PSSC semi - cylindrical cheese box full of water,
- (3) Image formation by lenses.

Newton's experiments with prisms and colors are described in narrative form in Section 22.8, leaving it to the instructor to decide whether to demonstrate the phenomena or to encourage the students to perform the experiments themselves.

## 22.2 Films and Demonstrations

The PSSC film on Pressure of Light is a short, impressive and excellent instructional film that makes a significant impact when shown in connection with this material - particularly with reference to some of the remarks made in Section 22.1 about the non-visible effects of light incident on surfaces.

A useful demonstration (either in connection with this chapter or Chapter 23) is the classic experiment of the door bell ringing in the evacuated bell jar. In this case, emphasis should be placed on the fact that the propagation of light is independent of the presence or absence of air while the presence of air is necessary for the propagation of sound.

## 22.3 Equipment

Experiment 22.3: Plane mirror, polar graph paper, light source screened off to provide a narrow beam, white paper to cover table surface.

Experiment 22.4: Plane mirror, white paper on table, nails (capable of standing on their heads) or pins long enough to project above the mirror.

Experiment 22.5: Best buy is probably the Sargent-Welch ray box with optics (Cat. No. 3665A). One set-up is adequate for 2 to 4 students. For demonstration purposes one can use equipment such as the Optical Disk and accessories (Sargent-Welch Cat. Nos. 3675, 3675A) or the Black Board Optics Kit (Cat. Nos. 3666, 3666A).

Experiment 22.6: Ball to roll down ramp. The platform and ramp can be easily improvised out of commonly available materials. (Also available as complete set-up: Sargent-Welch Cat. No. 3508.)

Experiment 22.8: (Usually most effectively done as a demonstration.) Arc light, lens, slit, two identical glass prisms, projection screen or white wall.

22.4 Test and Examination Questions

Given an object and a mirror positioned as in the following diagram.

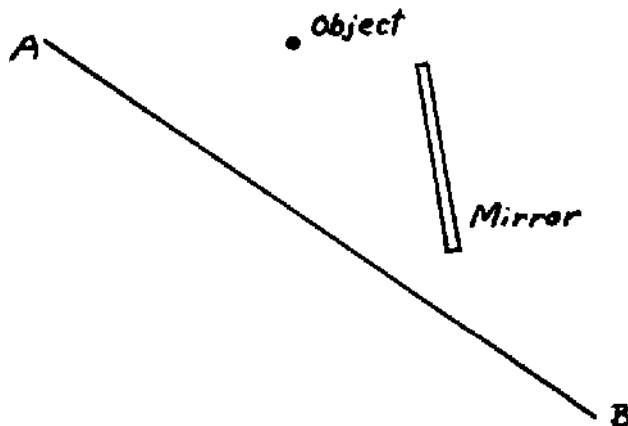

Explaining your reasoning very briefly, establish the range of positions along line AB from which you would be able to see the image of the object in the mirror.

Indicate the range of positions along AB from which an image would not be visible.

(a) Suppose the diagram at right represents the ray picture of light at an air-glass interface. Which medium is air and which is glass? Explain how you arrived at your answer.

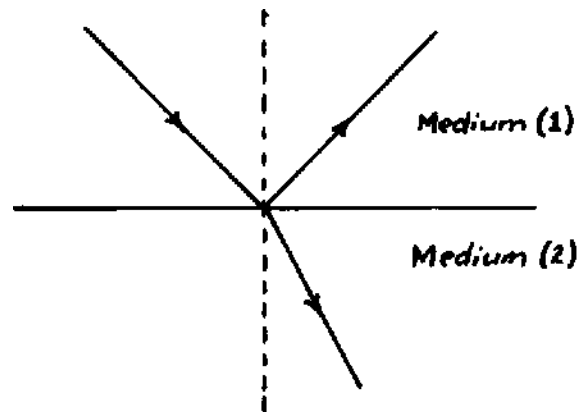

(b) Now suppose the diagram at right represents the ray picture at a partial barrier in the ripple tank. Which "medium" corresponds to shallow water and which to deep water?

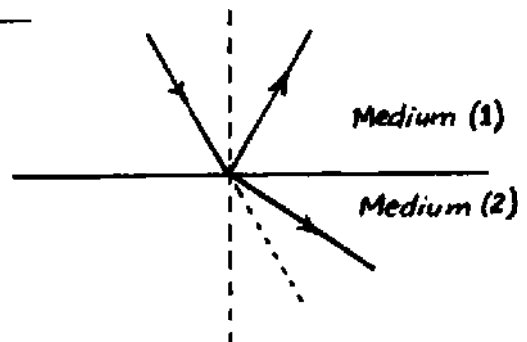

Suppose the diagram at right is a ray picture at an air-glass interface. Which medium is air and which is glass? Explain how you arrived at your answer.

If we see the reflection of the moon (or the sun) in a perfectly still lake, we see a sharp clear image of the moon. If the lake surface is ruffled by a breeze, we see a broad, fuzzy region of "glitter."

Explain both situations and the connection between them in terms of the law of reflection of light you have established in your laboratory observations.

---

In an illuminated room you can see any wall of the room from any location in which you stand. Is there any reflection involved in the interaction between incident light and the wall?

If not, how do you account for being able to see the wall? If yes, why do you not see images of other objects as you would if the walls were mirrors? Explain your reasoning in terms of the basic ideas and relationships you have been studying.

---

Explain in your own words how observations of the refraction of light force one to the conclusion that (a) if the particle model is valid, the velocity of light must be higher in glass than in air; (b) if the wave model is valid, the velocity of light must be lower in glass than in air.

---

The rectangle below represents a box with thin transparent or plastic sides and air on the inside. The box is immersed in water, and a beam of light is incident from the left as shown. Sketch the continuation of the beam through the box (ignoring any effects of the thin plastic). Draw the appropriate normals to the surface and indicate whether you require the beam to be refracted toward or away from the normal. Also explain the basis of your decision concerning the direction of the refraction.

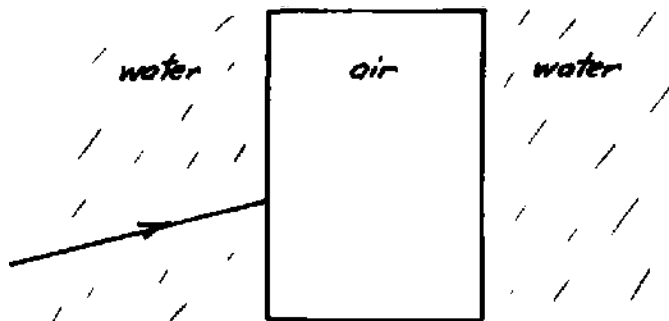

## Chapter 23

### Interference and Diffraction

#### 23.1 Content

This chapter concludes the work on wave phenomena and the development of the wave model for light. Group discussions can be very fruitful at this juncture, particularly for summarizing and analyzing the sequence of inference and reasoning and for assessing what has and has not been accomplished.

If necessary, Experiment 23.4 on two-source interference of sound and Problem 23.11.1 on measurement of wave lengths of light can be omitted. These experiments are, however, enthusiastically received by most students, and they add a great deal to the richness of the context in which students can place this entire sequence.

It will be noticed that, under pressure of space and time, Newton's rings and the various other varieties of thin film interference have not been mentioned. These phenomena readily lend themselves to optional experiment and investigation on the part of front-running students or to demonstration and group discussion.

#### 23.2 Equipment

Experiments 23.2, 23.3: Ripple tank with continuous wave generators (line source and point sources), hand stroboscope, e.g. Damon Cat. No. 50049.

Experiment 23.4: Equipment corresponding to that utilized in Project Physics Handbook (2nd edition), Experiment 3-18; Oscillator such as Damon Cat. No. 50046; pair of 3-inch loudspeakers such as Damon Cat. No. 50047. A "stethoscope" made by attaching a short length of rubber tubing to the stem of a funnel is helpful in localizing regions of constructive and destructive interference.

Experiment 23.5: Ripple tank, continuous straight-wave generator, barriers to make openings of various widths, obstacles of various widths to study "shadows." "Grating" barriers with 2, 3, 4, 5, 6 openings having a spacing of about 3 cm between centers (can be made by cutting "teeth" in strip of plywood).

Experiment 23.7: File cards and pins for making small holes. Point source of light (show case bulb end on or mask a larger source). Show case bulb for line source.

Experiment 23.8: Cornell plates with multiple slits and gratings (e.g.



Cornell Slit Film Grating, Cat. No. 460. Macalaster Scientific Co., Route 111 & Everett Turnpike, Nashua, N.H. 03060; or Ealing-Hoover Diffraction Plates, Cat. No. 25-7501. Ealing Corp., 2225 Mass. Ave., Cambridge, MA 02140.) Show case bulb. Laser.

Experiments 23.10, 23.11: Diffraction gratings (coarse and fine), gas discharge tubes (helium, neon, argon, mercury, atomic hydrogen), color filters, meter stick.

### 23.3 Test and Examination Questions

(A number of the learning objectives stated in Section 23.12 directly suggest appropriate test questions.)

---

(Reproduce a ripple tank two-source interference pattern and ask for a description of how the waves are superposing (constructively or destructively) at some particular point.)

(b) Suppose that we leave the wavelength unaltered but bring the two sources somewhat closer together. How will the pattern shown be altered? (Remember our metaphor of the opening or closing of a fan. You may refer to that, or make a very quick sketch, or both.)

(c) Suppose that we return to the condition shown in the figure, and, without altering the separation between the sources, increase the wavelength of the waves. How will the pattern shown be altered? Give a brief explanation of your prediction.

---

(Reproduce a two-slit interference pattern formed by light.)

(a) As a matter of experimental fact, how is this pattern altered if the two slits are placed closer together? (Give a very brief description or make a quick sketch.)

(b) In your own words, give a statement of how these observations support a wave model for the nature of light. Indicate how a particle model fails to be satisfactory under these circumstances.

(c) Suppose that the figure shown above was made with blue light. Suppose that a second picture is now made with red light without changing the spacing between the slits. As a matter of experimental fact, how does the pattern change? How do you interpret this experimental fact in terms of the difference between red and blue light? Explain your reasoning.

(Reproduce a ripple tank two-source interference pattern and indicate a point P on one of the nodal or antinodal loci.)

Let us treat the above figure as though it were a full scale representation of the ripple pattern. Using a ruler directly on the figure, measure the distances between point P and the two sources, and from these distances calculate the wave length of the wave trains. (Explain your reasoning briefly.) Compare your result with a direct measurement of the wave length. Do the two values agree or disagree with each other within the uncertainty of the measurement?

---

Sketch the interference pattern you would expect to observe in the ripple tank if you had two point sources oscillating exactly out of phase with each other (i.e. one is emitting a crest at the instant the other is emitting a trough and vice versa). Explain your sketch in your own words.

---

Explain in your own words why, as of the end of Chapter 23, we choose to say that "light behaves like a wave of some sort rather than as a stream of particles." Cite all the evidence you are able to bring together. (An integral part of such a discussion is a specific examination of the internal consistency of the entire point of view.) Include in your discussion an indication of why it is that we come to view each color of light as being associated with its own particular wave length.

---

(a) Report the values for wave length of different colors of light that you obtained in performing the experiment in Problem 23.11.1. (The most frequently used unit of length when dealing with this very minute scale is  $10^{-8}$  cm, one one-hundred-millionth of a cm. This unit is called "one Angstrom" (1 Å) in honor of a famous Swedish spectroscopist.) Report your values in Angstrom units.

(b) Atoms are known to have diameters of the order of 1 or 2 Ångstroms while molecules have dimensions of the order of several Ångstroms. About how many times larger than the dimensions of atoms and molecules are the wave lengths of visible light?

In light of the values discussed above, assess the possibility of our actually "seeing" an atom or a molecule by illuminating it with visible light. (In presenting your line of reasoning, go back to the effects observed in the ripple tank when propagating wave trains encounter objects of different sizes along their path. What happens when the obstacle is large relative to the wave length, very small relative to the wave length, etc.?)



3000

THƯ VIỆN  
Khoa học và  
kỹ thuật T.Ư

Lt  
3872  
19 87

K  
K  
3